

Instrucciones de montaje · Assembly Instructions

MARTHA 120

ES · IMPORTANTE: A CONSERVAR PARA FUTURAS CONSULTAS. LÉASE ATENTAMENTE.

EN · IMPORTANT: PLEASE KEEP FOR FUTURE REFERENCE. READ CAREFULLY.

FR · ATTENTION: CONSERVER POUR CONSULTER AU FUTUR.

IT · IMPORTANTE: LEGGERE ATTENTAMENTE LE ISTRUZIONE. TENERE PER FUTURE CONSULTAZIONE.

PT · IMPORTANTE: MANTENHA PARA FUTURAS CONSULTAS. LÉASE ATENTAMENTE.

R · ВАЖНО: СОХРАНИТЕ ДЛЯ ДАЛЬНЕЙШЕГО ИСПОЛЬЗОВАНИЯ. ВНИМАТЕЛЬНО ПРОЧИТИТЕ.

A · — لامعتسالا لابق اديج أرقا. ةعجارم لل ظفح ا. ماه

CN · 重要事项：保留以备将来参考，请仔细阅读。

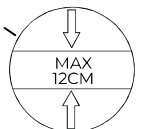
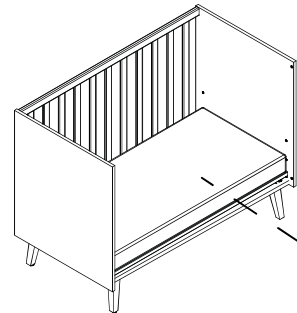
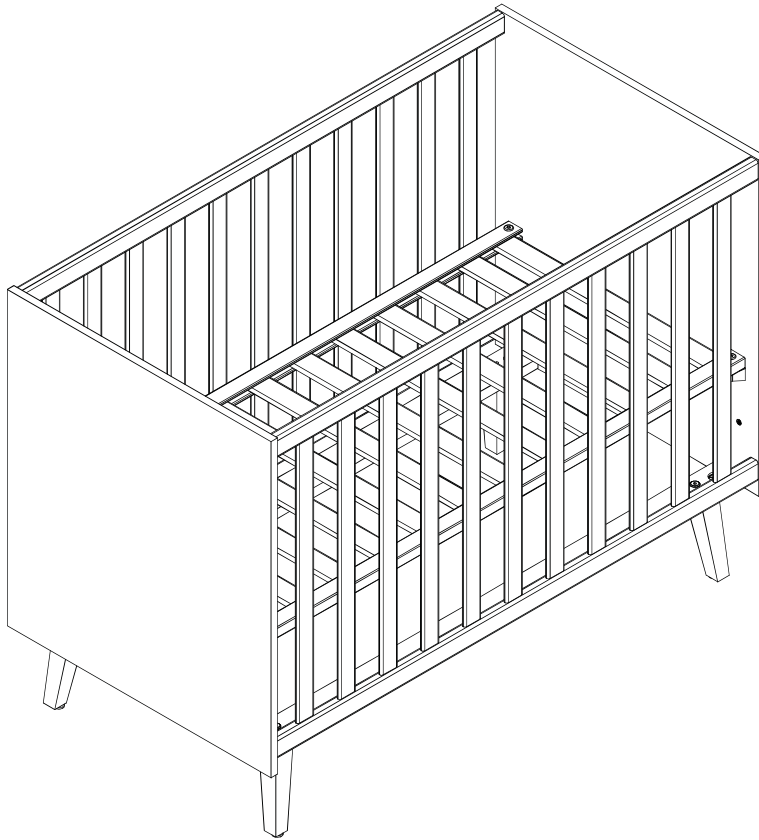

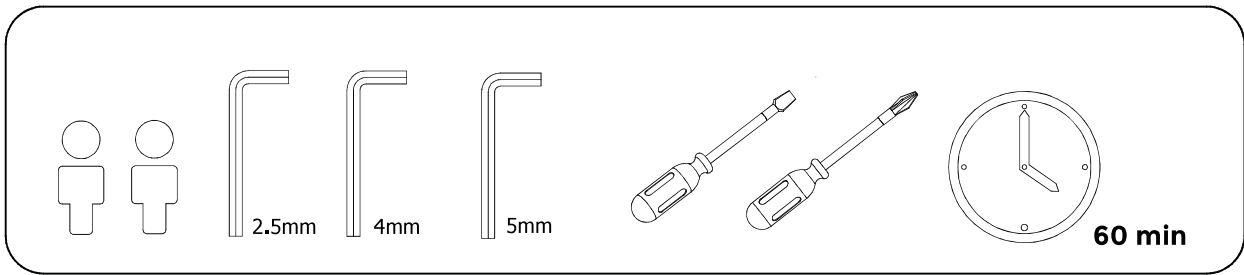

C11297
x1 (2.5mm)

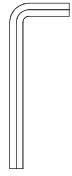

C07914
x1 (4mm)

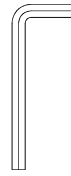

C07506
x1 (5mm)



C10313
x4

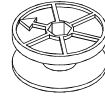

C07376
x4

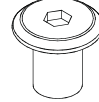

C11286
x4

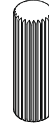

C01419
x8 (7.8x25)



C01247
x4 (6x25)

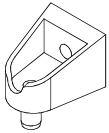

C09547
x4

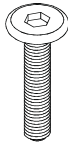

C07893
x4 (M6x35)



C10638
x4 (M6x17)



C14738
x8



C14740
x8



C10987
x4

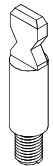

C14739
x8

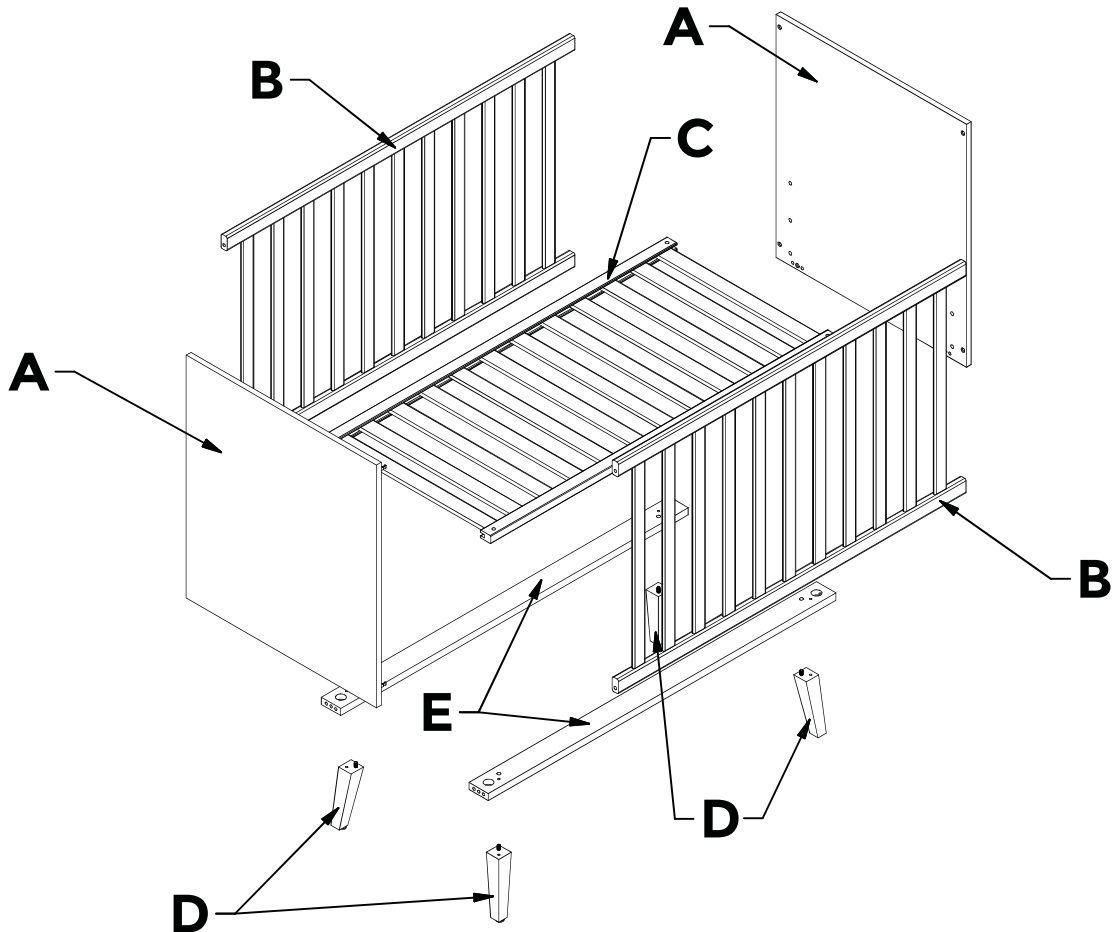

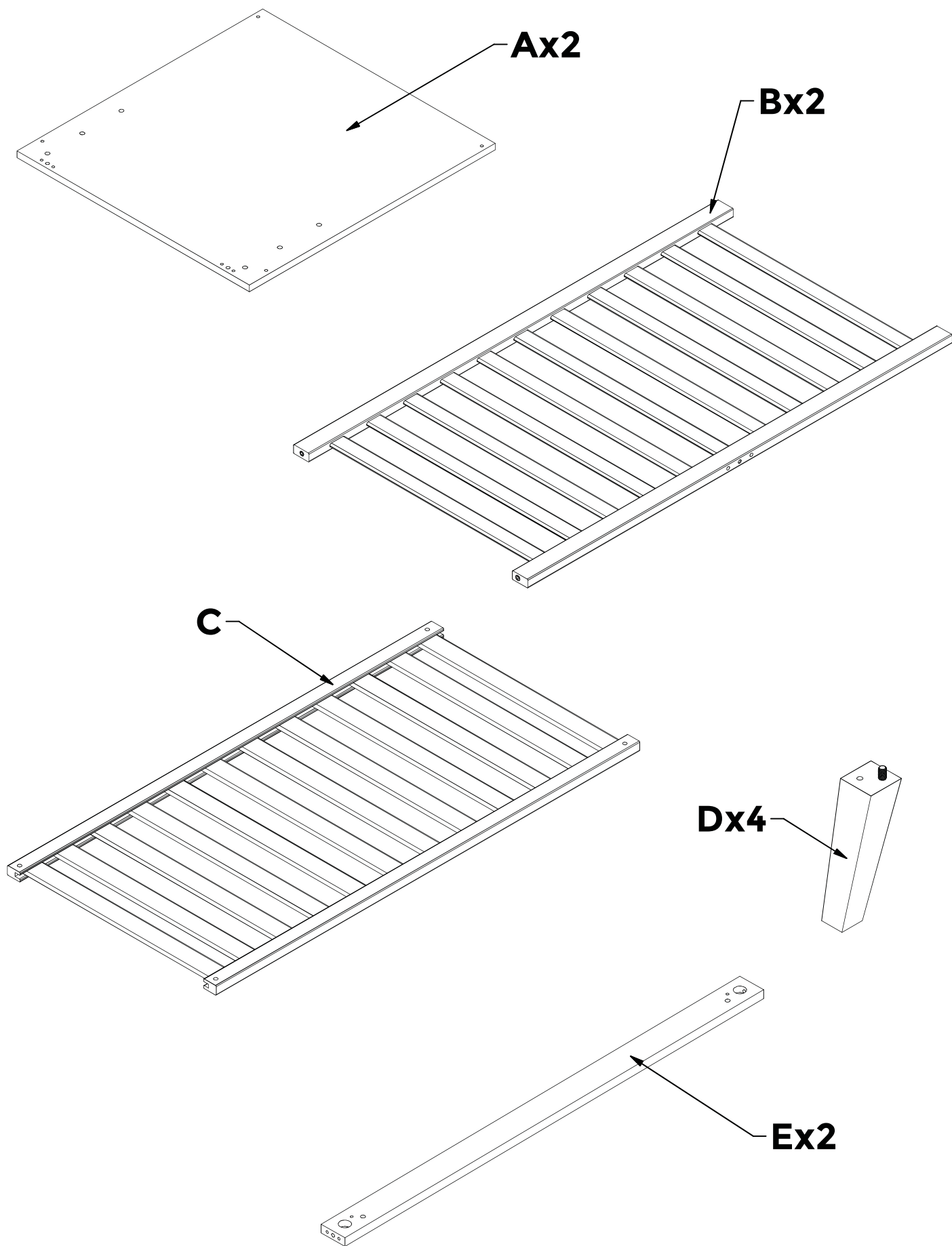

1

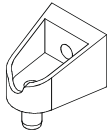
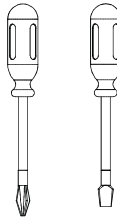

C09547
x4

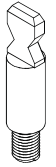

C14739
x8



C10638
x4 (M6x17)

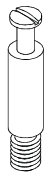

C10313
x4

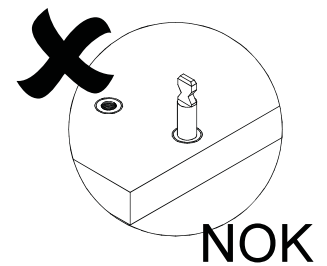
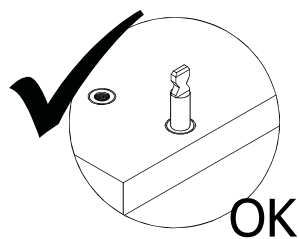
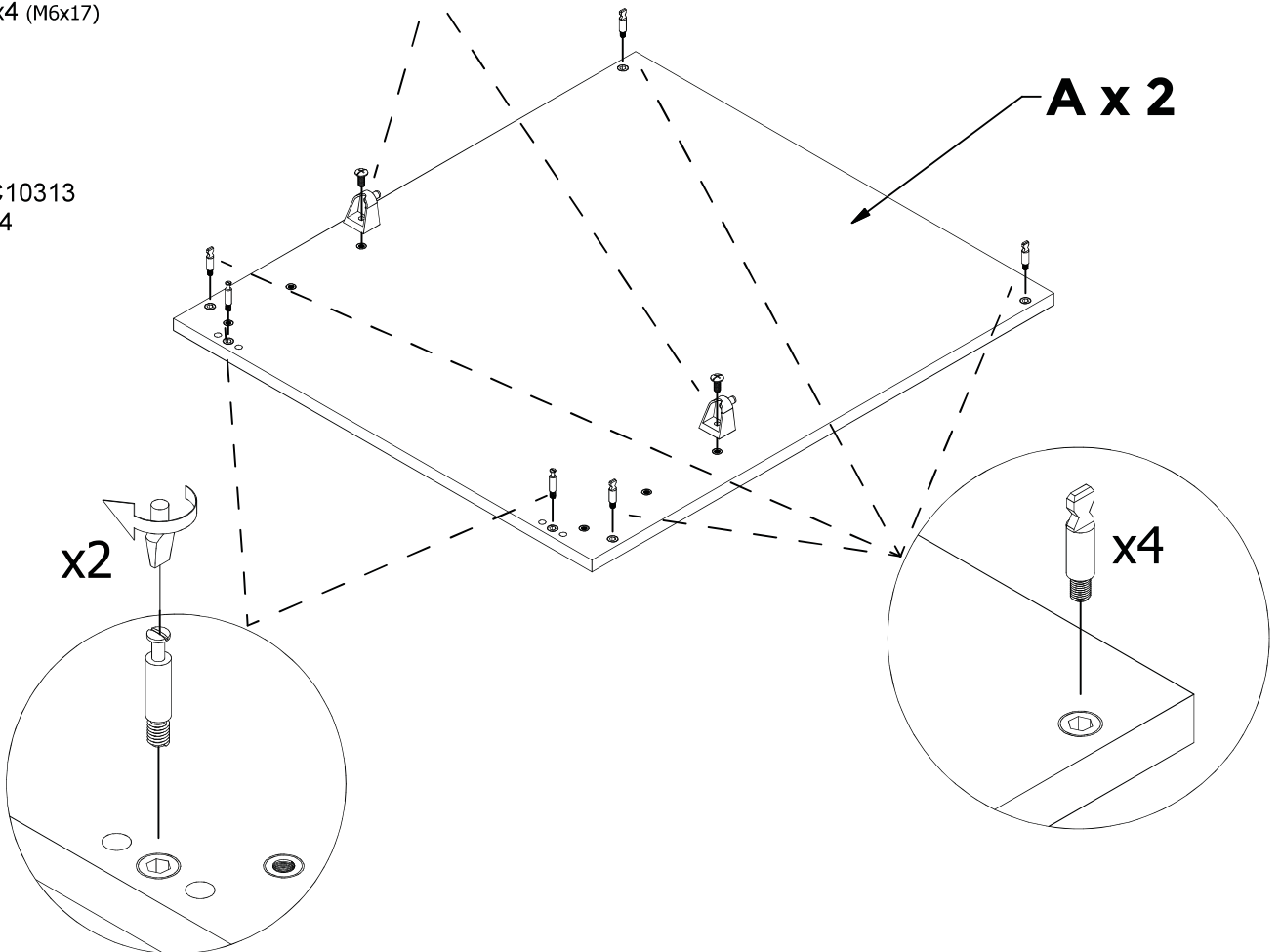
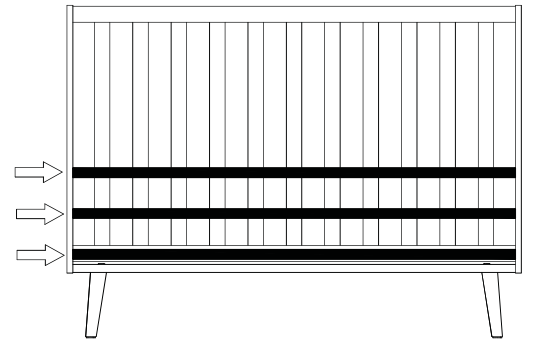
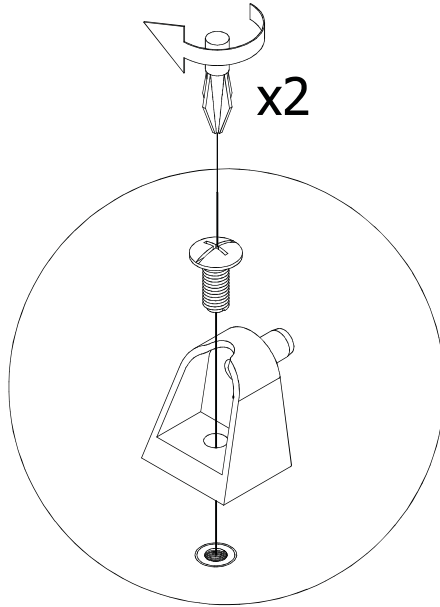

2

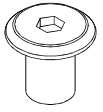
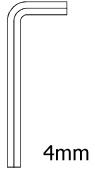

C11286
x4

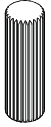

C01419
x8 (7.8x25)

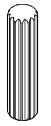

C01247
x4 (6x25)



C10987
x4

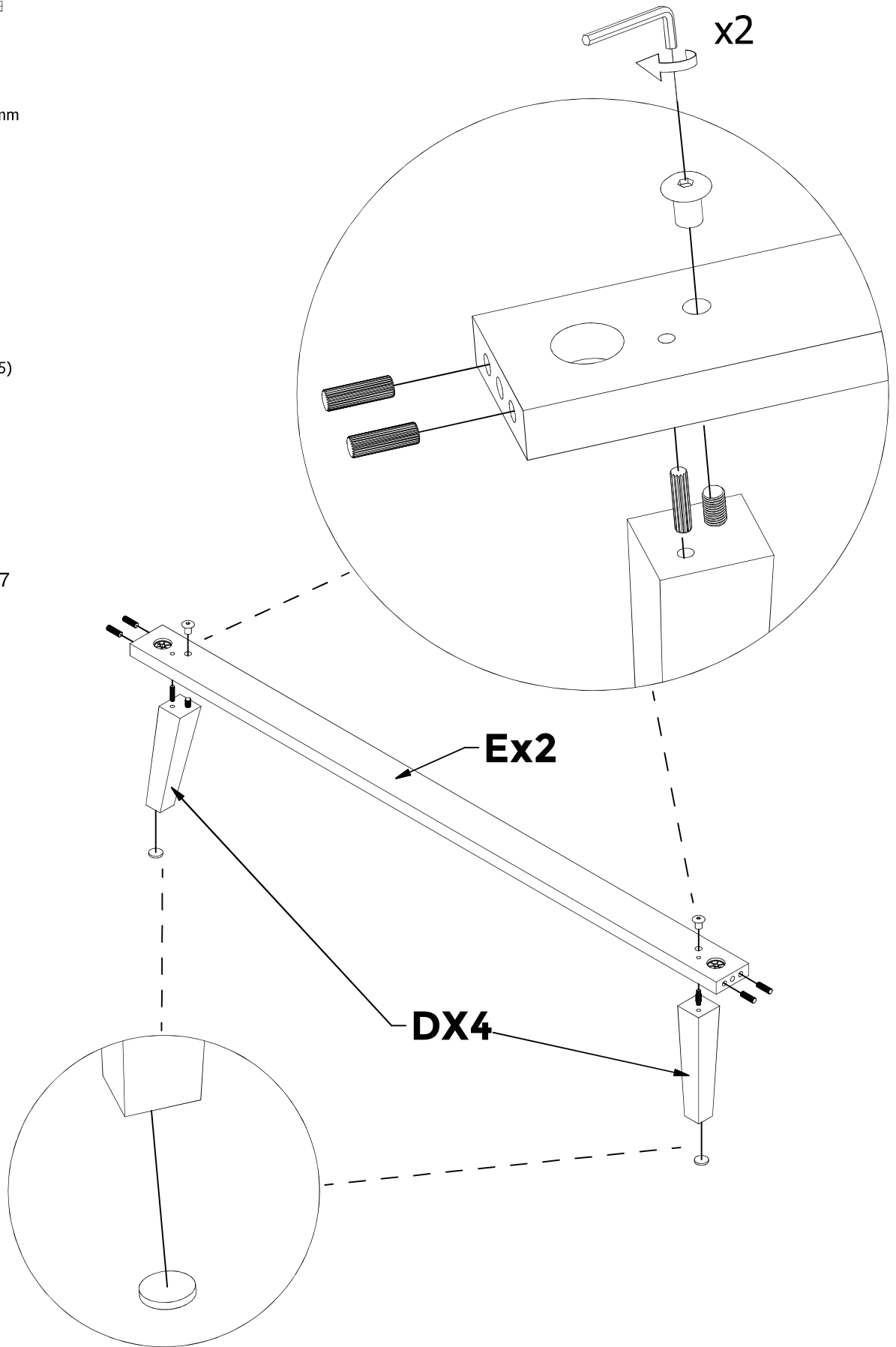

3

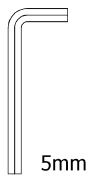

C07376
x2

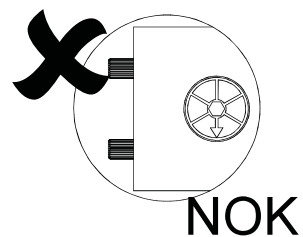
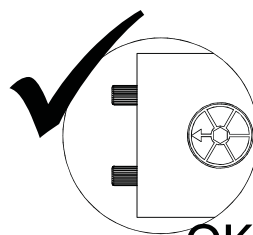
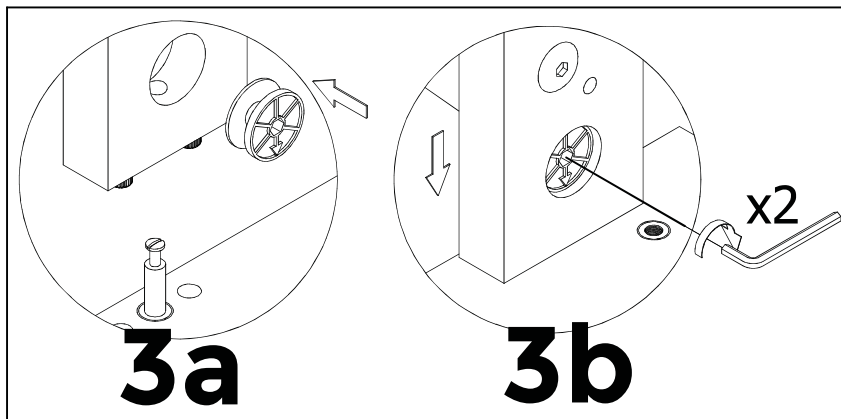
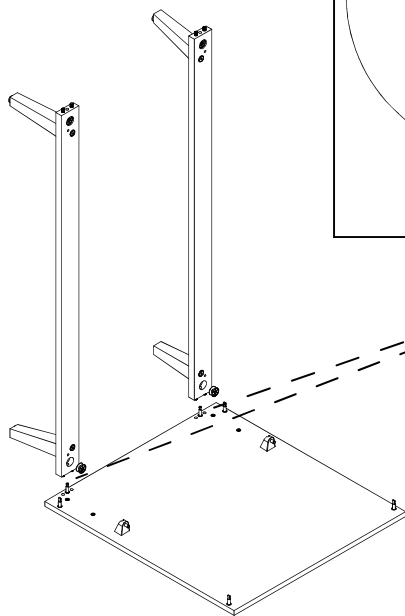

4



C14738
x4



C14740
x4

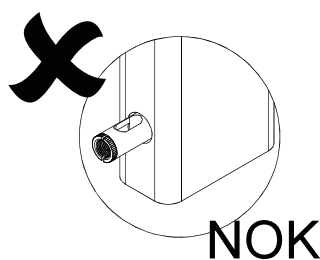
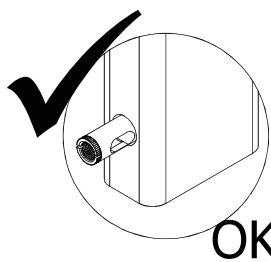
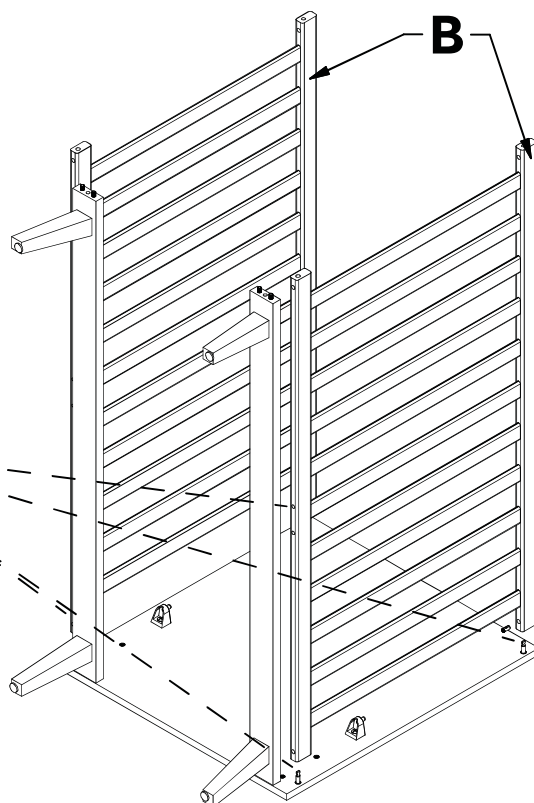
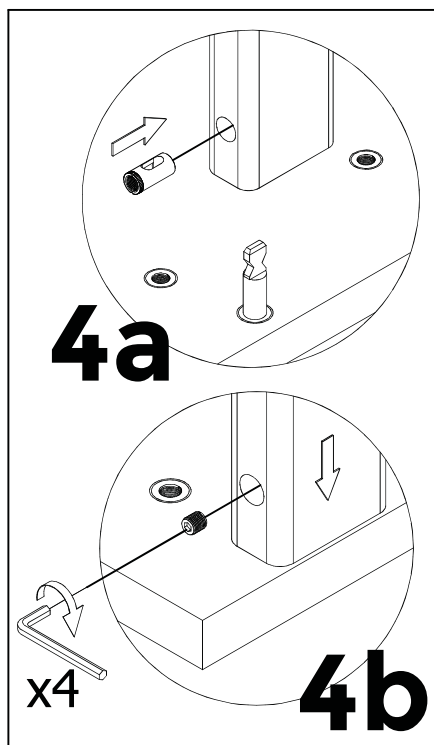

5



C07376
x2



C14738
x4

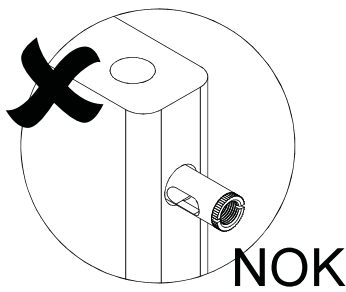
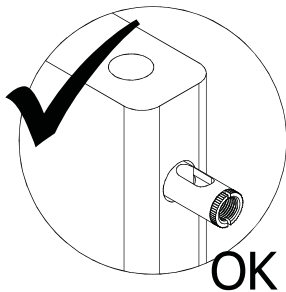
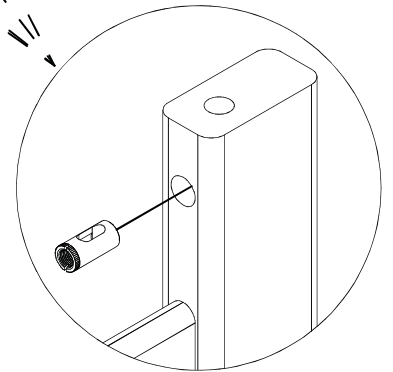
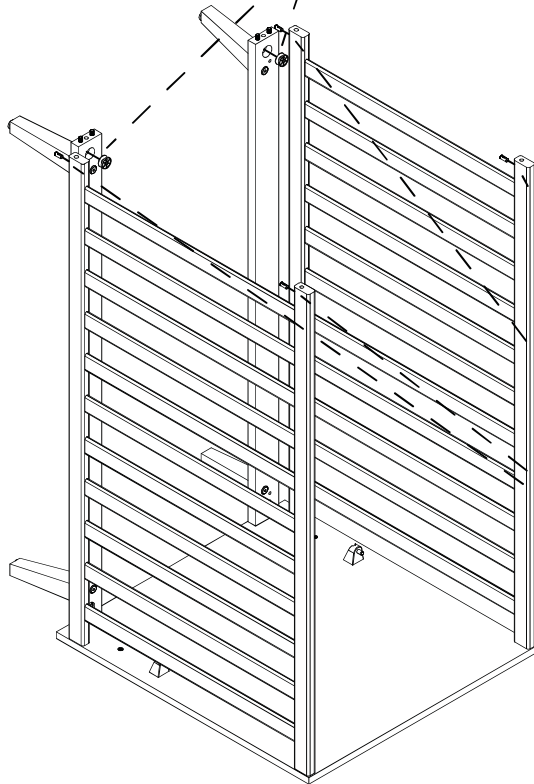
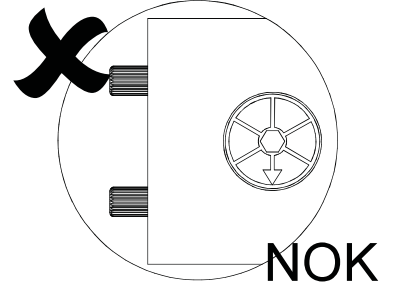
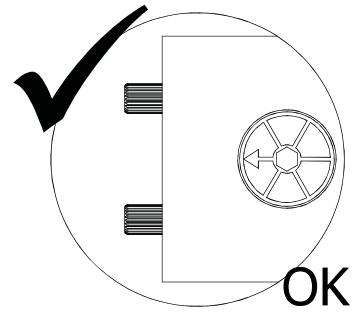
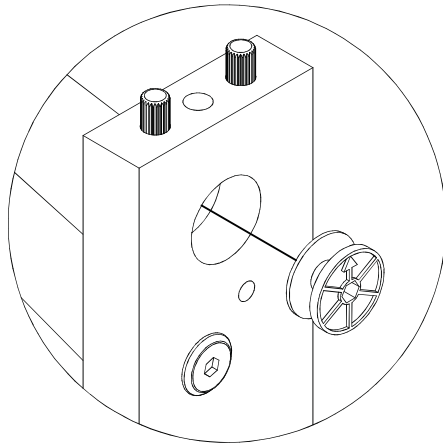

6

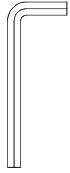

C14740
x4

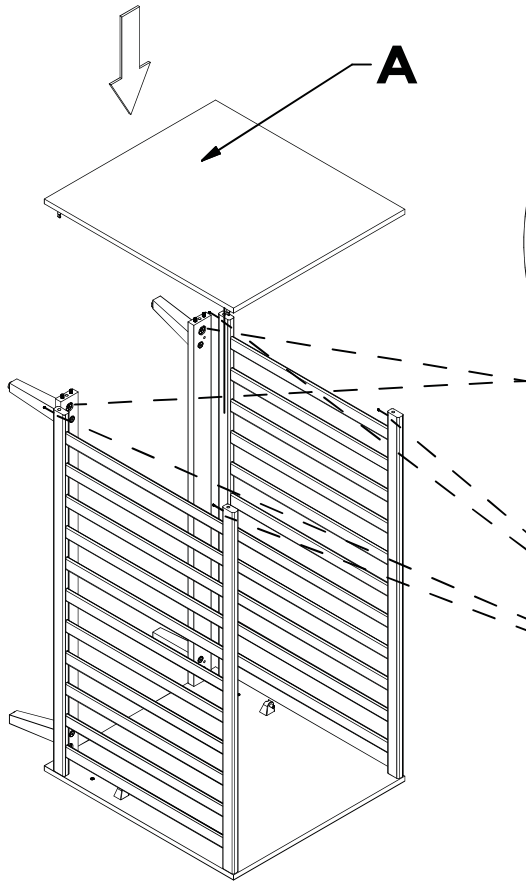

6a

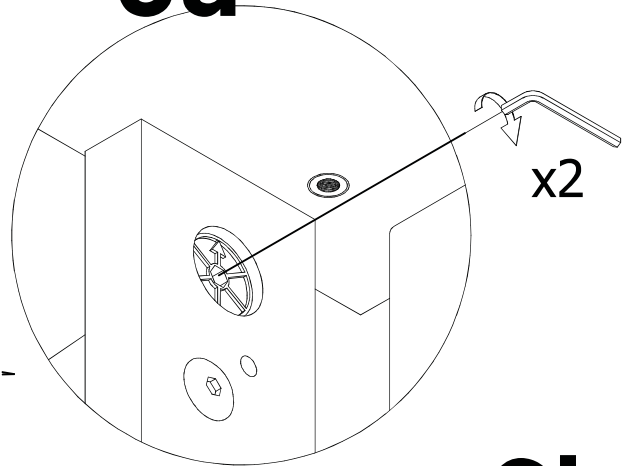

6b

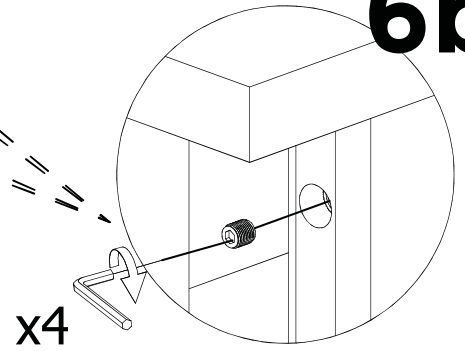

7



4mm

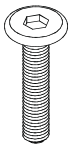

C07893
x4 (M6x35)

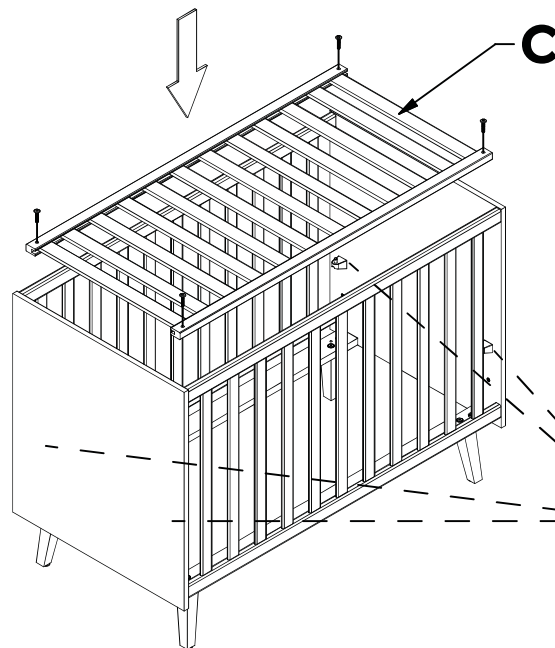

x4

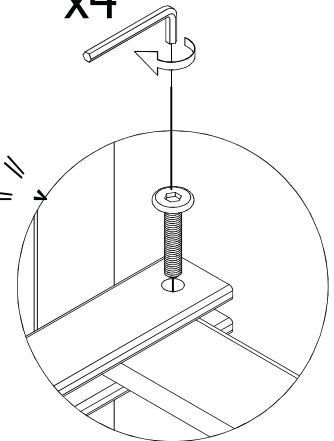



OK!!

• ES •

- 1: **Advertencia:** Tener presente el riesgo de situar la cuna cerca del fuego o de otras fuentes de calor, tales como aparatos de calefacción eléctricos, de calefacción a gas, etc.
- 2: **Advertencia:** No utilizar la cuna si cualquiera de sus componentes está roto, deteriorado o falta, y utilizar únicamente piezas de repuesto aprobadas por el fabricante.
- 3: **Advertencia:** No dejar ningún objeto en la cuna ni situar esta cerca de otro producto, que pudiera proporcionar un punto de apoyo para el pie del niño, o presentar riesgo de asfixia o de estrangulamiento, por ejemplo, cuerdas, cordones de cortinas o persianas, etc.
- 4: **Advertencia:** No utilizar más de un colchón en la cuna.
- 5: La cuna está lista para su uso únicamente cuando los mecanismos de bloqueo están en funcionamiento. El funcionamiento debe comprobarse cuidadosamente antes de utilizar la cuna.
- 6: La posición más baja es la más segura, lo más conveniente es utilizar siempre esta posición desde el momento en que el niño sea capaz de sentarse.
- 7: El espesor del colchón elegido debe ser tal, que la altura interna (es decir, la distancia entre la superficie del colchón y la parte superior de la estructura de la cuna) sea al menos de 500 mm con el somier en la posición más baja, y al menos 200 mm con el somier en la posición más alta.
- 8: El tamaño mínimo del colchón a utilizar en la cuna será de entre 117 cm de largo y 60 cm de ancho. La longitud y anchura debe ser tal que el hueco entre el colchón y los laterales y los cabeceros, no debe ser mayor de 30 mm.
- 9: Para su limpieza utilizar un paño suave humedecido.
- 10: Para prevenir riesgos de caídas cuando del niño sea capaz de salir de la cuna, la cuna no debe utilizarse más para ese niño.
- 11: Todos los dispositivos del montaje deben estar siempre convenientemente ajustados y los tornillos no deben estar sueltos, pues el niño podría pincharse o engancharse con la ropa o accesorios (cordones, collares, cadenas para chupetes de bebé, etc...), lo que supondría un peligro de estrangulación.
- 12: Los dispositivos de montaje deberían estar siempre convenientemente ajustados, y debén verificarse periódicamente y, si es necesario reajustarse.

• EN •

1. WARNING: Be aware of the risk of open fire and other sources of strong heat, such as electric bar fires, gas, fires in the near of the cot.
2. WARNING: Do not use the cot if any part of it is broken, torn or missing and use only spare parts by the manufacturer.
3. Do not leave anything in the cot or place near the cot any product, which could provide a foothold or present a danger of suffocation or strangulation, e.g. strings, blind/curtain cords, etc.
4. WARNING: do not use more than one mattress in the cot.
5. Statement that a cot is ready for use only when the locking mechanisms are engaged and check carefully that they are fully engaged before first use.
6. If the height of the cot-base is adjustable, a statement that the lowest position is the safest and that the base should always be used in that position when the baby is old enough to sit up.
7. Thickness of the mattress shall be such that the internal height (surface of the matterss to the upper edge of the cot frame) is at least 500 mm in the lowest position of the cot base and at least 200mm in the highest position of the cot base.
8. The minimum size of the mattress to be used in the crib will be between 117 cm long and 60 cm wide. The length of the matterss shall be such that the gap between the mattress, the sides and ends does not exceed 30 mm.
9. Cleaning instructions: For deaning please use a wet and smooth cloth
10. Statement to prevent injury from falls once the child is able to climb out of the cot, the cot shall no longer be used for that child
11. All assembling devices must always be conveniently adjusted and the screws should not be loose as the child may get hurt or get hooked up with clothes or accessories (laces, necklaces, chains for baby pacifiers, etc ...), which could suppose a danger of strangulation.
12. All assembling devices must always be conveniently adjusted and they must be checked up regularly, readjusting them if necessary.

• FR •

- 1: Attention: Soyez conscient du lieu où vous situez le lit, dû aux risques de feux provenant de différentes sources de chaleur tels que les appareils de chauffage électriques, de gas, etc..
- 2: Attention: Ne pas utiliser le lit s'il lui manque un composant, ou bien il est cassé ou endommagé. Et, utiliser uniquement les pièces de rechange du fabriquant.
- 3: Attention: Ne jamais laisser un objet dans le lit, ainsi que le situer près d'un autre produit qui pourrait faciliter un point d'appui du pied de l'enfant, ou pourrait présenter un risque d'asphyxie ou d'étranglement, par exemple cordes, lacets, tirettes, etc....
- 4: Attention: Ne pas utiliser plus d'un matelas par lit.
- 5: Le lit est prêt à être utilisé uniquement quand le mécanisme de blocage est en marche. Le fonctionnement doit être vérifié soigneusement avant d'utiliser le lit.
- 6: Quand l'enfant est capable de rester assis, il convient de situer le sommier dans la position la plus basse.
- 7: Pour que l'épaisseur du matelas que vous avez choisi soit le correct, il faudra prendre note de l'information suivante; Si le sommier du lit se trouve dans la position plus basse, il faut compter au moins 500mm de distance entre la surface du matelas et la partie supérieure de la structure du lit. Si, au contraire le sommier est en position plus haute, la distance requise sera de 200mm.
- 8: La taille du matelas doit avoir un minimum de 117 cm de longueur et 60 cm de largeur. La distance entre le matelas et les côtés, tête et pied de lit ne doit pas dépasser 30 mm.
- 9: Pour son entretien, nettoyer avec un chiffon doux et humidifié.
- 10: Le lit ne devrait plus être utilisé quand l'enfant est capable de sortir tout seul afin d'éviter les risques de chute.
- 11: Tous les dispositifs de montage doivent toujours être bien ajustés et les vis ne doivent pas être lâche, puis l'enfant pourrait se piquer ou s'accrocher avec vêtements ou accessoires (des cordons, des colliers, des chaînes de sucettes, etc ...), ce qui supposerait un risque d'étranglement".
- 12: Tous les dispositifs d'assemblage doivent toujours être bien ajustés et contrôlés régulièrement, et les réajuster si c'est nécessaire.

• IT •

- 1: AVVERTENCIA. Non collocare la culla vicino a fuoco o qualsiasi fonte di calore, come per esempio stufe elettriche o a gas.
- 2: AVVERTENCA. Non utilizzare la culla nel caso in cui uno dei pezzi necessari al montaggio siano rotti o mancanti. Utilizzare solamente i pezzi di montaggio approvati dal fabbricante.
- 3: AVVERTENCIA. Non lasciare alcun oggetto nella culla nè posizionare quest'ultimo vicino ad altri oggetti che possano rappresentare un punto d'appoggio per il piede del bambino o che possano provocare soffocamento o asfissia, per esempio corde o cordoni di tende e persiane ecc ecc.
- 4: AVVERTENCIA. Non utilizzare più di un materasso nella stessa culla.
- 5: La è pronta per essere montata solamente quando gli ingranaggi del bloccaggio sono in funzione. Il funzionamento deve essere attentamente verificato prima di usare la culla.
- 6: Collocare il materasso nella posizione più bassa rappresenta la opzione più sicura e conveniente. Si consiglia di utilizzare questa opzione a partire dal momento in cui il neonato è in grado di stare seduto.
- 7: Lo spessore del materasso scelto deve essere tale che l'altezza interna (ossia, la distanza tra la superficie del materasso e la parte superiore della struttura della culla) sia per lo meno di 500 mm collocando il somier nella posizione più bassa o per lo meno 200 mm se si colloca il somier nella posizione più alta.
- 8: Il formato minimo del materasso da utilizzare per la culla sarà di 117 cm di lunghezza e 60 cm di larghezza. La lunghezza e lo spessore del materasso devono essere tali che la distanza tra il materasso e la struttura laterale della struttura non superi i 30 mm.
- 9: PULIZIA. Per la pulizia della culla si consiglia di utilizzare un panno morbido inumidito.
- 10: Per prevenire rischi quando il neonato è in grado di uscire dalla culla, quest'ultima non dovrà utilizzarsi più.
- 11: Tutti i dispositivi di montaggio devono essere accuratamente aggiustati e i vite non devono essere sciolti, perché il bambino potrebbe bucarsi o agganciarsi con i vestiti o accessori (micelci, collane, cetene per ciucci, etc...).
- 12: Tutti i dispositivi di montaggio devono sempre essere regolate correttamente, e devono essere controllati regolarmente, e riaggiustare-li se fosse necessario.

• PT •

- 1: Atenção: Colocar a cama longe de fontes de calor, como aparelhos eléctricos, a gás, etc.
- 2: Atenção: Não utilizar a cama se qualquer um dos seus componentes estiver deteriorado ou se faltar alguma peça. Utilizar unicamente peças do fabricante.
- 3: Atenção: Não deixar nenhum objecto dentro da cama, nem colocá-la perto de um ponto de apoio para os pés da criança, pois há o risco de asfixia ou estrangulamento: por exemplo cordas, cordões de cortinas ou persianas, etc.
- 4: Atenção: Não utilizar mais do que um colchão na cama.
- 5: A cama está pronta a usar somente quando os mecanismo de bloqueio estão em funcionamento. Este funcionamento deve experimentar-se antes utilizar a cama.
- 6: A posição mais baixa do estrado é a mais segura. É conveniente utilizar sempre esta posição desde a altura em que a criança se senta.
- 7: A espessura do colchão escolhido deve ser tal, que a altura interna (quer dizer a distância entre a superfície do colchão e a parte superior da estrutura do berço) seja de pelo menos 500mm com o estrado na posição mais baixa e de pelo menos a 200mm com o estrado na posição mais alta
- 8: O tamanho mínimo do colchão a utilizar na cama é de 170 cm de comprimento e 60 cm de largura. O comprimento e largura devem deixar uma distância entre os laterais da cama e as cabeceiras nunca maior que 30mm.
- 9: "Instruções de limpeza" : Para limpar utilizar um pano suave humedecido
- 10: Para prevenir os riscos de quedas quando a criança é capaz de sair da cama sozinha, não utilizar mais a cama para
- 11: "Todos os dispositivos de montagem devem estar sempre convenientemente ajustados e os parafusos não devem estar soltos pois o bebé poderia ferir-se, engatar-se na roupa ou acessórios (cordões, porta-chupetas de bebé, etc.), evitando o perigo de estrangulação.
- 12: Todos os dispositivos de montagem devem sempre ser convenientemente ajustados e devem ser verificados periodicamente e ajustados de novo se necessário.

• R •

1. Важно: Помните об опасности открытого огня и других источников сильного тепла, таких как электрические и газовые плиты и т.д. в непосредственной близости от кровати.
2. Важно: Не используйте кровать, если некоторые из деталей повреждены или отсутствуют, всегда используйте запасные части, предоставленные производителем.
3. Важно: Не оставляйте никакие предметы в кровати и рядом с ней, которые могут служить опорой для ног ребенка или представлять опасность удушья ребенка, например, веревки, шнуры от занавесок, жалюзи и т.д.
4. Важно: Не используйте более одного матраса в кровати.
5. Кроватью можно пользоваться только после того, как запорные механизмы установлены и тщательно проверена их надежная работа.
6. Если высота ложа кровати поддается регулировке, самая нижняя позиция является самой безопасной, и эту позицию необходимо использовать, когда ребенок достаточно вырос, чтобы самостоятельно сидеть.
7. Толщина матраса должна быть такой, чтобы внутренняя высота (от поверхности матраса до края кровати) составляла не менее 500 мм в нижнем положении ложа кровати и не менее 200 мм в верхнем положении ложа кровати.
8. Минимальный размер матраса для кровати должен быть от 170 см в длину до 60 см в ширину. Размер матраса должна быть такой, чтобы зазор между матрасом и сторонами кровати не превышал 30 мм.
9. Инструкция по чистке: Для чистки, пожалуйста, используйте влажную и мягкую ткань.
10. Для предотвращения риска выпадения ребенка из кровати и получения травмы, когда ребенок может вылезти из кровати самостоятельно, не используйте больше кровати для этого ребенка.
11. При монтаже все детали должны быть правильно закреплены, а винты тщательно затянуты. Несоблюдение этого требования может повлечь травмы и порезы у ребенка либо допустить возможность контакта крепежных деталей с одеждой и аксессуарами (шнуры, цепочки, крепления для сосок и т.д.), что повышает опасность удушья.
12. Все собранные механизмы должны быть правильно закреплены, отрегулированы, регулярно проверяться и корректироваться при необходимости.

• AR •

تي ان عبق ة ارق ل ام ام تهال ا

1. ريرس ل ا طي ح م ي ف ب ع ل ل د ح و ف ا ر ش ا ن و د ل ا ف ط ا ل ا ك ر ت ي غ ب ن ي ال
2. ح ال ص ل ا ي ت ح ي س ي م و م د خ ت س ت ن ا ي غ ب ن ي ال ر س ل و ا ؤ ؤ ؤ ر س ل ك م ت ا ا ا ا
3. ل ف ل ا ا ذ ل ر ث ك ا م ا د خ ت س ا ن ك م ي ال س ي س ي م و د ح و ف و ق و ل ا و ا و ك ر ل ا س و ل ج ل ا ع ي ط ن ت س ي ل ف ل ا ل ن و ك ي ا م د ن ع
4. ل ف ل ا ل ا ل ع ر ط خ ي ا ب ن ج ت ر ي م ا س ا ر ب ا ت د د ش و ا م ا م ت ا ه ل ي د ع ت ا م ا م ت ا ة د ع ا ص ت م ل ا ؤ ؤ ؤ ا ل ا ع ي م ج ي ل ع ب ج ي
5. م م و م و ن و د م د خ ت س ت ن ا ي س و م ق ل س ي غ ب ن ي ال
6. ب ص ن م ي ل ع ا ي ف ة ع ا ق ع م ل م 200 ن ع ل ق ي ال ي و ل ع ل ا ب ن ا ج ل ا ل ا ل ا ش ا ر ف ل ا ح ط س ن م ت ي ح ب ة ك ا م س ا ه ل ا م ا د خ ت س ل ا ش ا ر ف ي ل ع ب ج ي
7. ... خ ل ا ز ا غ ل ا و ة ي ة ا ب ر ه ل ك ل ا ة ي ف د ت ل ا و د م ن م ة ب ي ر ق ل ل ا ق ط ا ن م ل ا ي ف ؤ ا ر ج ل ا د و ج و ن ع م ج ا ن ل ا ق ي ر ج ل ا ر ط خ ر ج ل ا
8. ب ق ا د ا ل ا ر ي غ ه ي ف ل ا ز ي ال ل ف ل ا ل ا ن ا ي ح ي ف ر ي ر س ل ا ن م ت ا ل ج ع ل ا ع ن م
9. ة ي ن ع م ل ا ق ا ن ت خ ا ل ا ر ط خ ع م س ب ا ل م ل ا ة ة و ق ا و ل ل ص ح ت ن ا ن ك م ي و ا ة ص ر ق ل ف ل ا ل ا و ر ي م ا س ي خ ر ت ال ف و س
10. ل ا ذ ن م ر ث ك ا ر ي ر س ل ا ا ه م ا د خ ت س ا ي غ ب ن ي ال ر ي ر س ل ا ن م ج و ر خ ل ا ل ع ل ع ل ر د ا ق ل و ك ي ا م د ن ع ل ف ل ا ل ا ق و ق س ر ط ا خ م ب ن ج ت ل
11. ا ه ب ق ش ت و ل ف ل ا ل س ب ا ل م ي ف ق ل ع ت د ق ش ي ح ة ت ب ا ث ر ي غ ق ل ا ح ي ف ر ي م ا س م ل ا ك ر ت م د و م ة م ا ل ل ك ش ب ب ي ك ر ت ل ا ؤ ؤ ؤ ل ك ط ب ض ب ج ي
12. ق ا ن ت خ ا ل ا ر ط خ ل ه ض ر ع ي د ق ا م م (غ ل ا) ت ا ي ا ه ل ل ا و ل ل س ل ا ل ا و ة ة ا ل ق ل ا و ة ي ز ل ا ط ئ ا ر ش) ل ث م ت ا ر ا و س س ل ك ا ي ف و ا م ا ل م ز ل ن ا ا ه ل ي د خ ت و ا ي ر و د ا م ن ق ق ح ت ا ل ا ي غ ب ن ي و ة ة ا د ة ف ص ب و م ا ل ل ك ش ب ب ي ك ر ت ل ا ؤ ؤ ؤ ا ل ط ب ض ب ج ي ف

• CH •

注意，仔细阅读

1. 附近无人看管时，不应让儿童在摇篮中单独玩耍。
2. 任何部件如有损坏，或摇篮有破损，修好前不要使用。
3. 当孩子可以单独坐、跪或站时，就不应再使用此摇篮。
4. 所有安装组件都务必正确调节并拧紧螺钉，以免给婴儿带来危险。
5. 摇篮的吊篮在未装支架时不应使用。
6. 所用床垫应有一定的厚度，从而使底板处于最高位置时，床垫表面到两侧上部的距离至少为 200 毫米。
7. 当摇篮附近有热源，如电暖器、燃气等时，应注意发生火灾的危险。
8. 当孩子处于无人看守时，应锁住摇篮车的车轮。
9. 螺钉不应松动，以免夹伤孩子或钩住其衣服，发生勒颈窒息的危险。
10. 所有安装设备均必须随时保持在方便调整状态，并螺钉不应出现松动的情况，因为可能会导致婴儿遭到刺伤，或是勾住衣服或配件的风险（如系带、项链、婴儿奶嘴链条等...），这些都可能产生窒息的危险性。
11. 安装的装置应随时保持合宜地调整，并定期进行检查，如果必要时，进行适度的调整
12. 安装的装置应随时保持合宜地调整，并定期进行检查，如果必要时，进行适度的调整