

MOISES
MO-1456 SMART LUCE
Instrucciones de Montaje

Fabricado en Valencia, España

-IMPORTANTE: A CONSERVAR PARA FUTURAS CONSULTAS. LÉASE ATENTAMENTE.

ES

EN -IMPORTANT: PLEASE KEEP FOR FUTURE REFERENCE. READ CAREFULLY.

FR -ATTENTION: CONSERVER POUR CONSULTER AU FUTUR.

IT -IMPORTANTE: LEGGERE ATTENTAMENTE LE ISTRUZIONE. TENERE PER FUTURE CONSULTAZIONE.

PT -IMPORTANTE: MANTENHA PARA FUTURAS CONSULTAS. LÉASE ATENTAMENTE.

R -ВАЖНО: СОХРАНИТЕ ДЛЯ ДАЛЬНЕЙШЕГО ИСПОЛЬЗОВАНИЯ . ВНИМАТЕЛЬНО ПРОЧИТИТЕ .





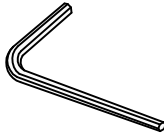

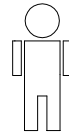

A - ماه. ظرف حا ذة عجم ارملد. أرقا اادي ج لبق لام عتسالا

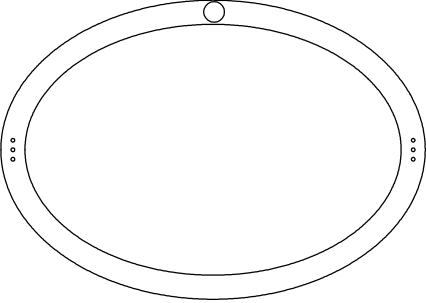
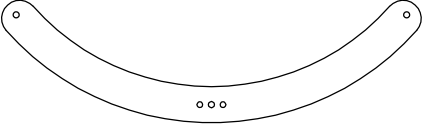
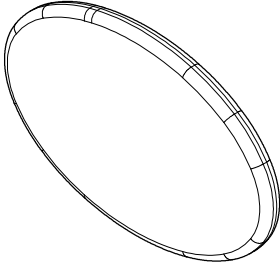
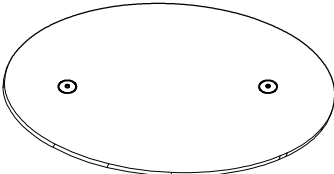
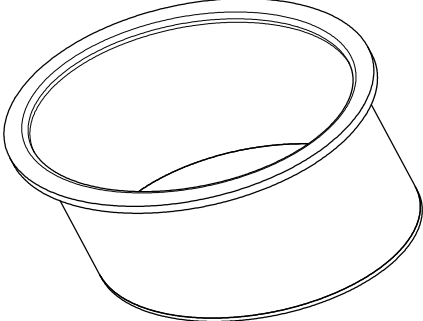

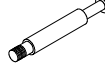
CN -重要事项: 保留以备将来参考, 请仔细阅读。

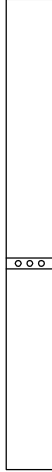
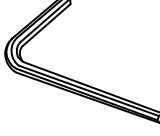



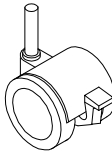

20'



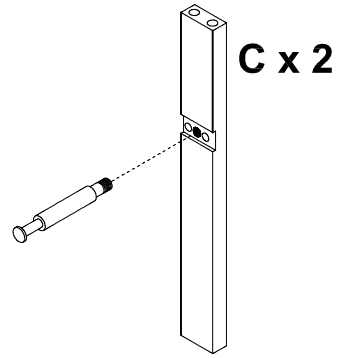
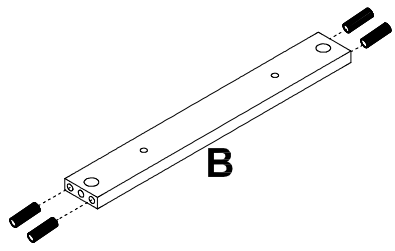

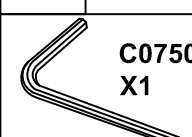

 <p>A x 1</p>  <p>D x 2</p>  <p>F x 1</p>  <p>E x 1</p>  <p>G x 1</p>	 <p>C01419 X4</p>	
	 <p>C06767 X2</p>	
	 <p>C07375 X2</p>	
	 <p>C07376 X2</p>	
	 <p>B x 1</p>  <p>C x 2</p>	 <p>C07506 X1</p>
	 <p>C07914 X1</p>	
	 <p>C07893 X10</p>	
	 <p>C07744 X4</p>	
	 <p>C04514 X2</p>  <p>C07496 X6</p>	

- 1.**
- 
 -  **C01419**
X4
 -  **C07375**
X2

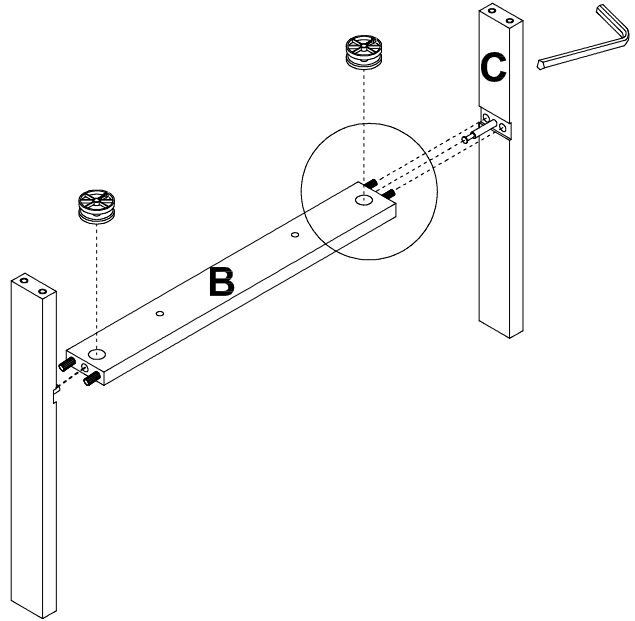
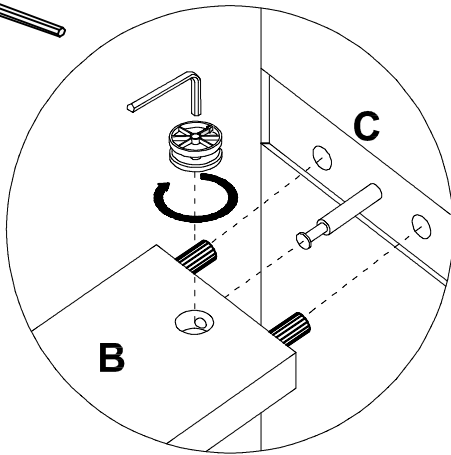

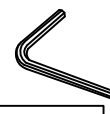
- 2.**
- 
 -  **C07506**
X1
 -  **C07376**
X2



- 3.**
- 
 -  **C07914**
X1
 -  **C06767**
X2
 -  **C07893**
X4

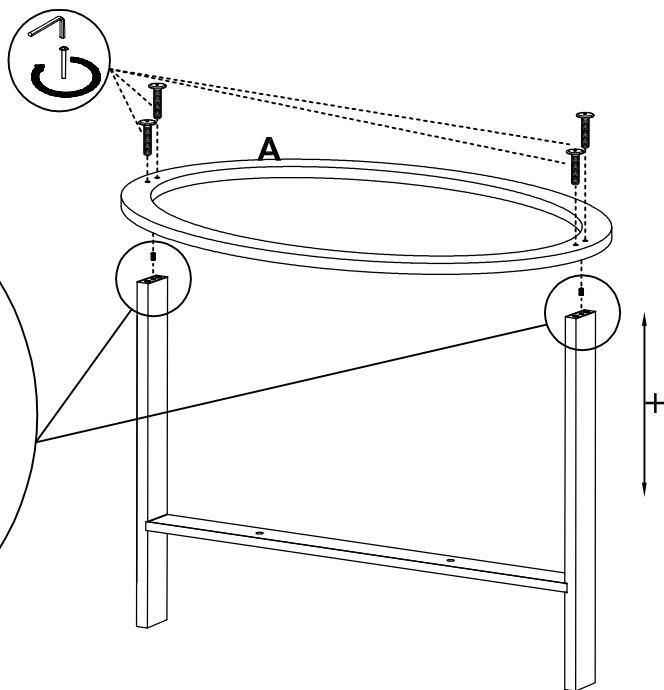
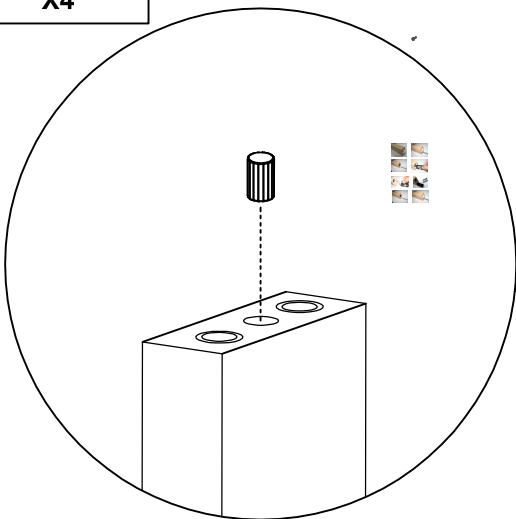

4.

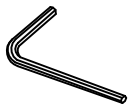

C07914
X1



C07893
X4

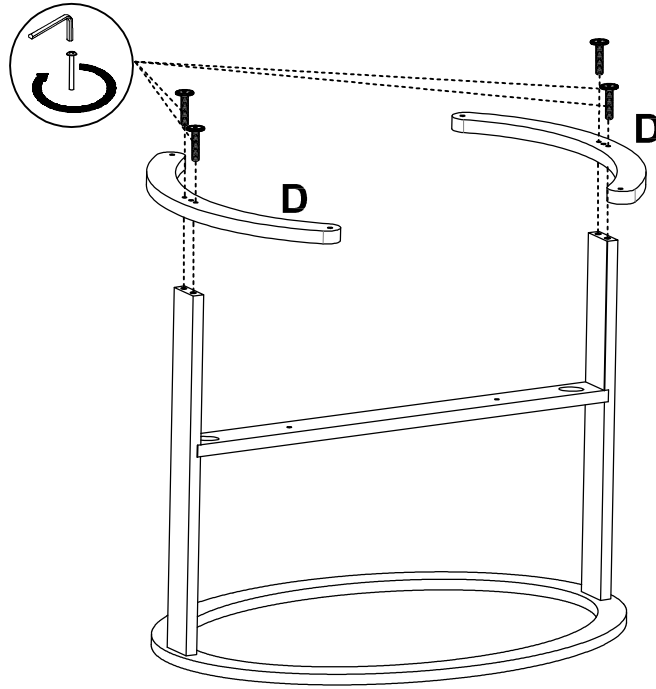

5.

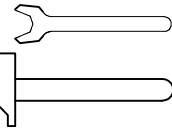

C07914
X1



C07893
X4



C07496
X6



C07744
X4



C04514
X2

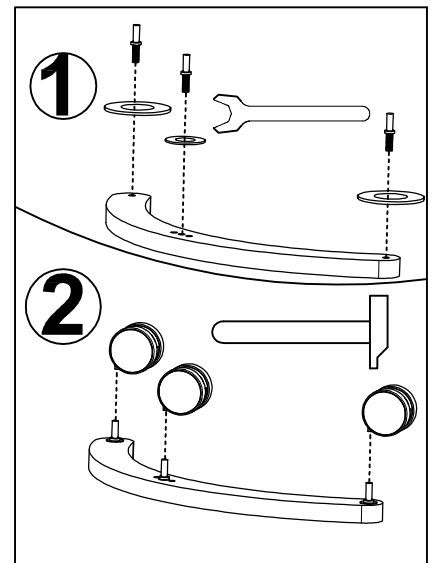
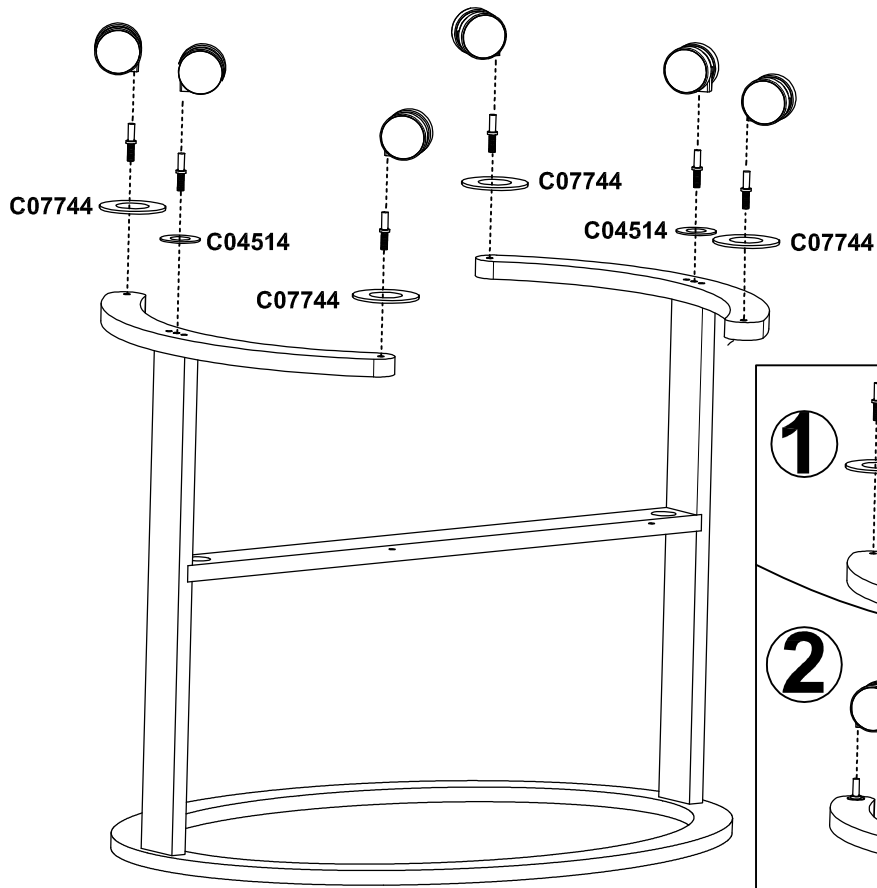

6.

7.

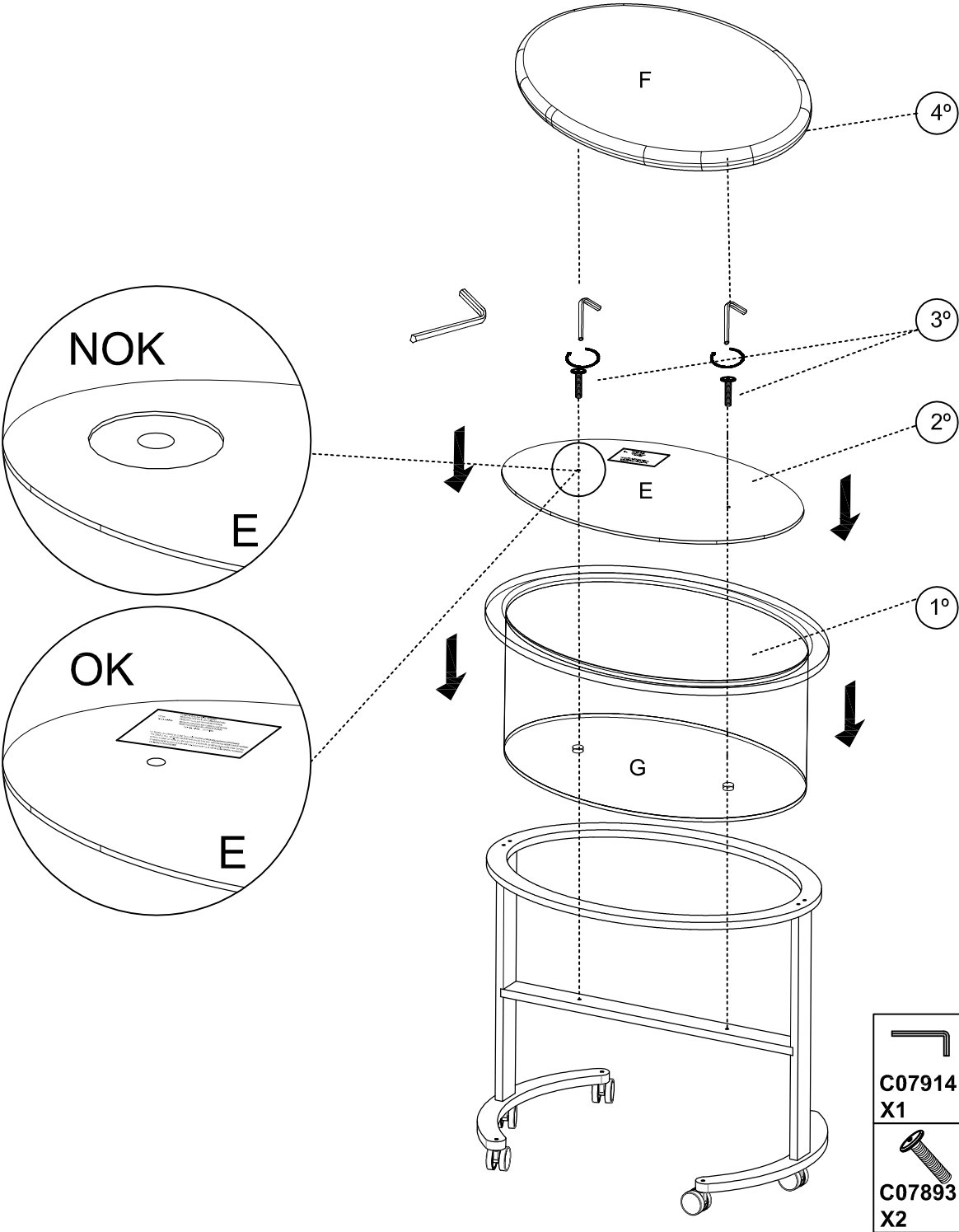

8.

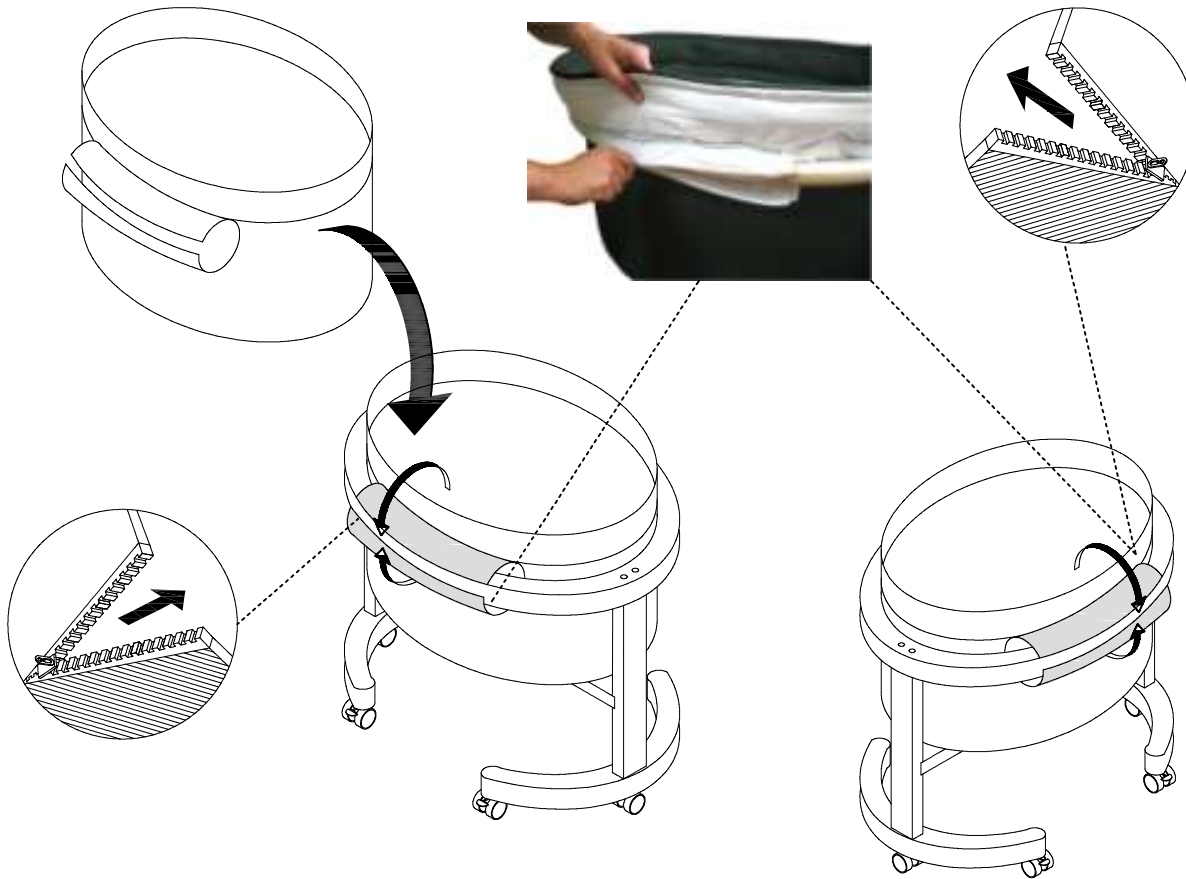

9.



(ES) -Altura máxima de colchón.
 (EN) -Maximum height mattress
 (PT) -Altura máxima COLCHÃO
 (FR) -Hauteur maximale MATELAS
 (IT) -Altezza massima del materasso.
 (CN) -床垫最大高度。
 (AR) شارف لل ول علأ
 (RU) Максимальная высота матраса

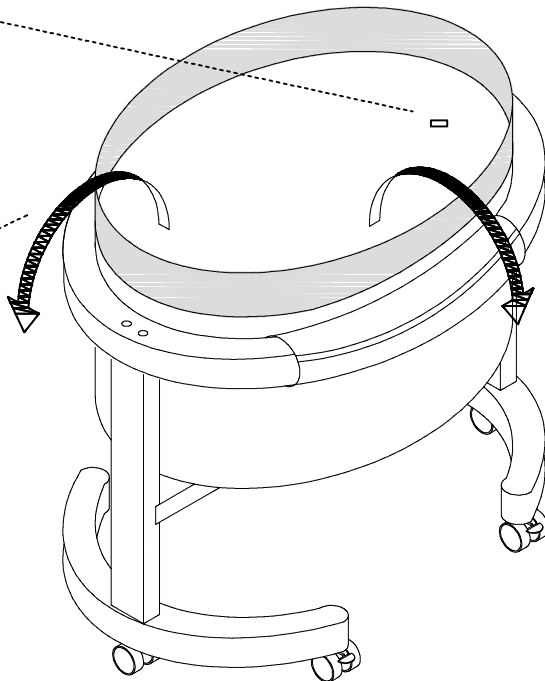

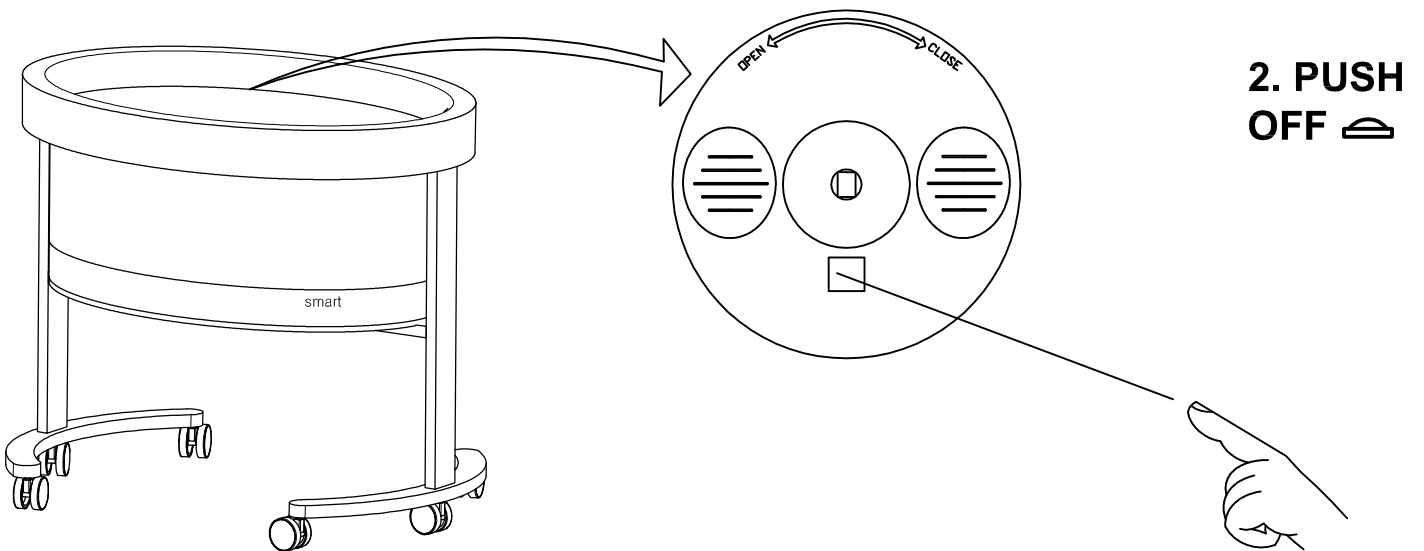
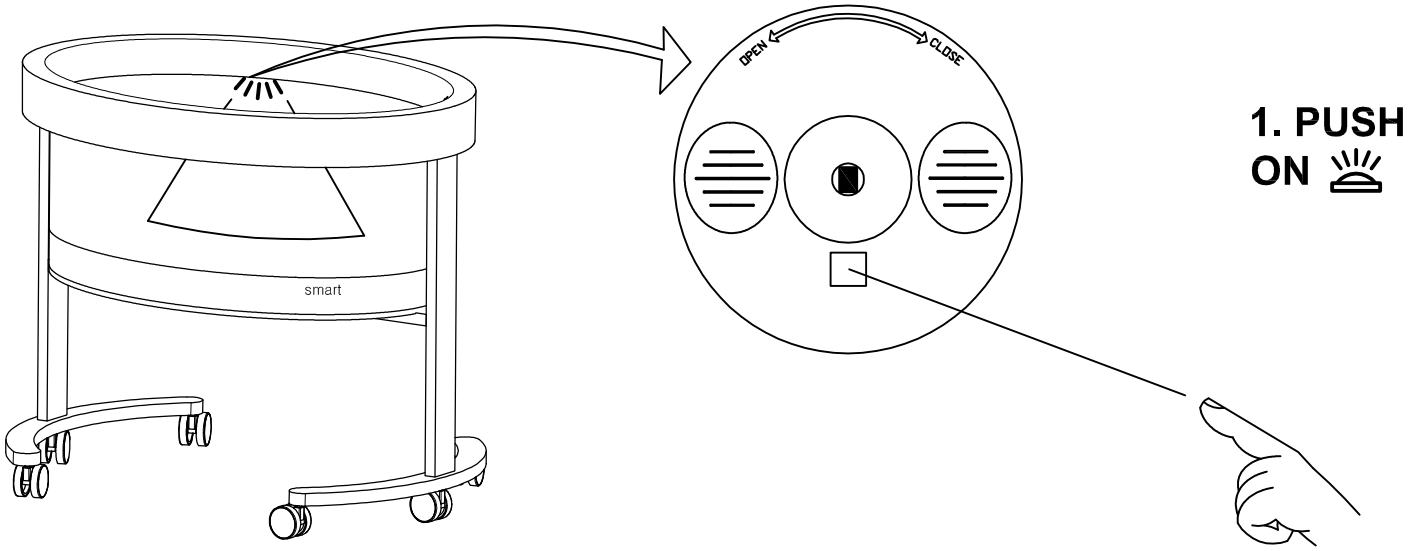



1.

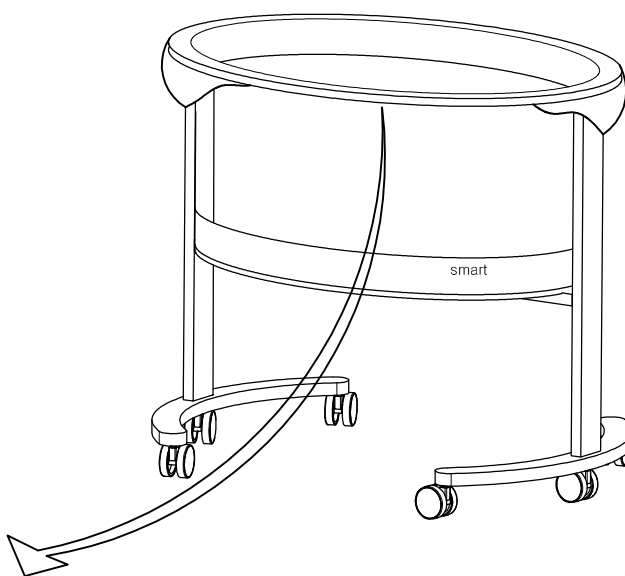
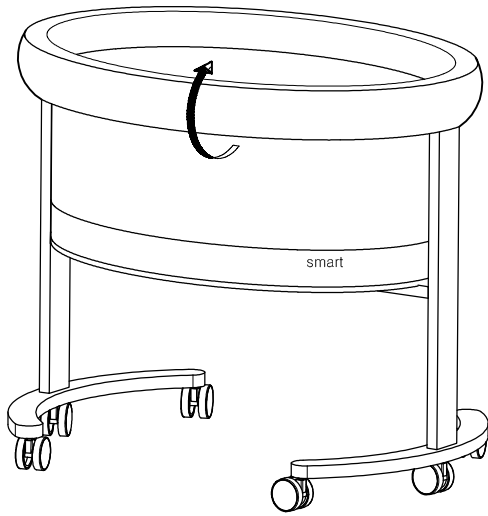

2.

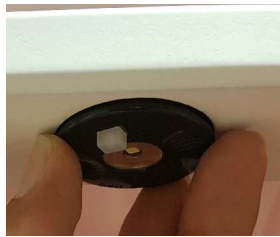

3.



4.



5.



6.

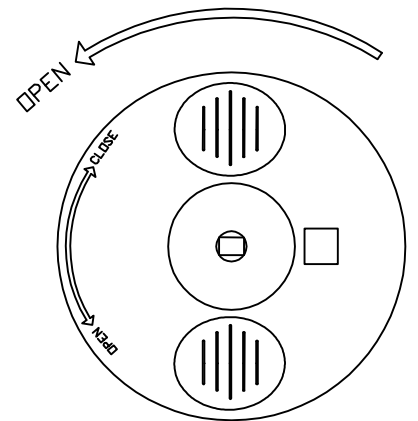

X3



3 PILAS LR44 (AG13)

3 BATTERIES LR44 (AG13)



7.



8.



9.

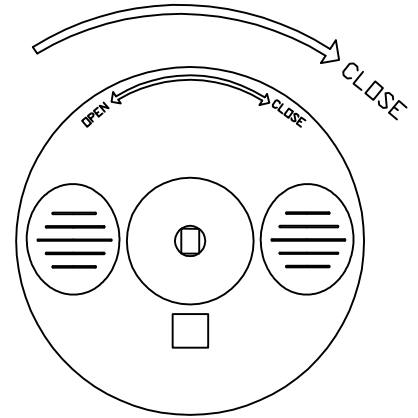

10.

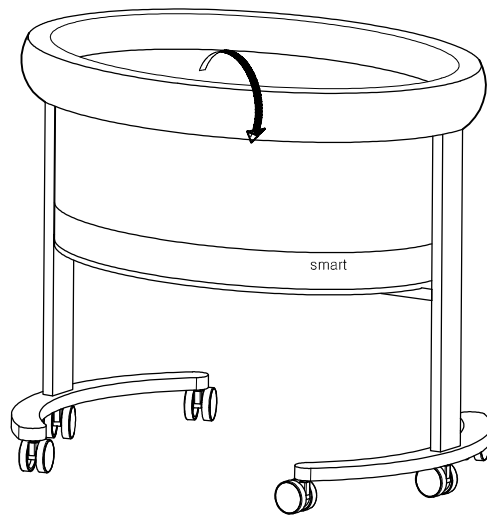

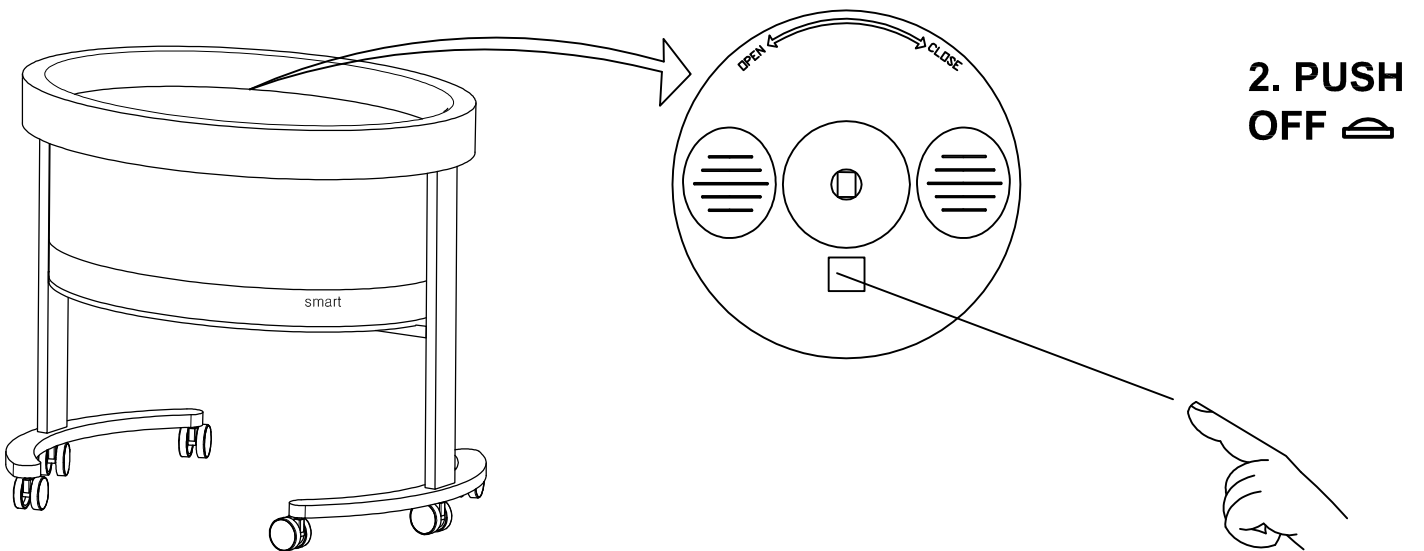
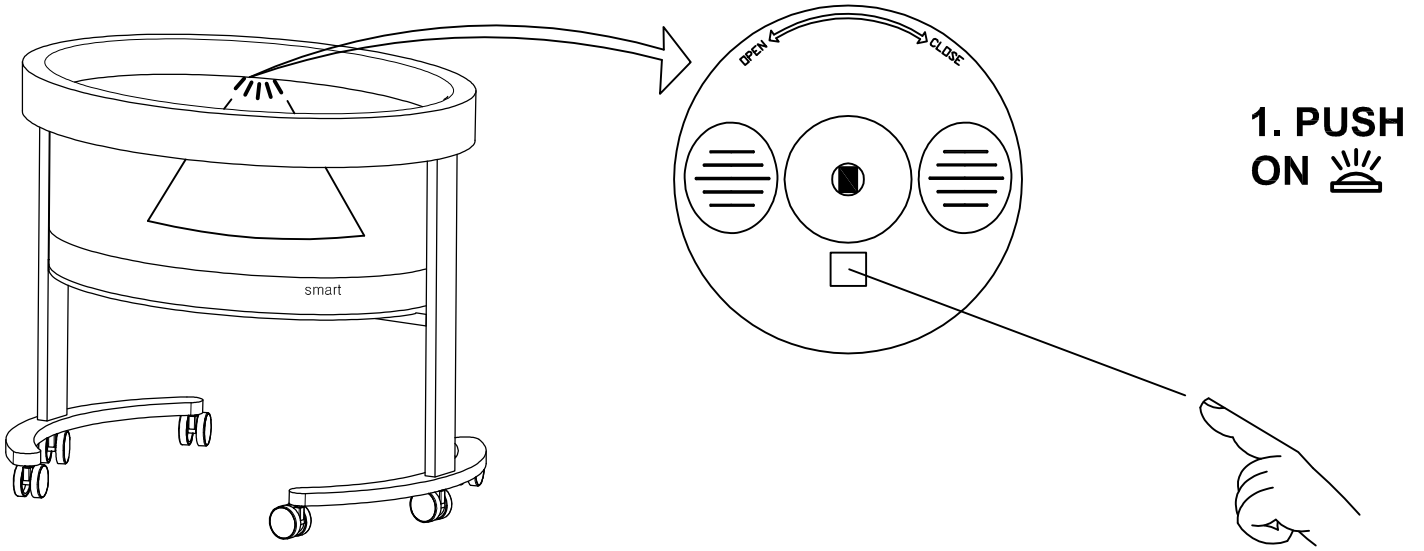

OK!!!

- ATENCION. LEER DETENIDAMENTE

(ES)

1. El moises debe ser convenientemente situado sobre un suelo horizontal.
2. No conviene dejar jugar a los niños solos sin vigilancia en las proximidades del moises.
3. En caso de que se rompa alguna pieza, o se quiebre el moises no debe ser utilizado hasta su reparación.
4. Cuando un niño pueda sentarse, arrodillarse o levantarse solo, el moises no deberá utilizarse más por ese niño.
5. Todos los dispositivos del montaje deben estar siempre ajustados y los tornillos perfectamente apretados para evitar cualquier peligro al bebé.
6. La canastilla del moises no deberá utilizarse sin su soporte.
7. El colchón a utilizar deberá tener un espesor de modo que desde la superficie del colchón hasta la parte superior de los laterales, sea, al menos, de 200 mm con la base en la posición más alta.
8. Aconsejamos utilizar siempre colchones que eviten la asfixia y con propiedades antiácaros.
9. Advertimos del peligro de incendio que supone la presencia de calor en las proximidades de la cuna como aparatos eléctricos de calefacción, de gas etc...
10. Bloquear las ruedas del moisés mientras el niño permanezca en él sin vigilancia.
11. Los tornillos no deberán aflojarse ya que el niño puede pellizcarse o sus ropas quedar atrapadas con el peligro de estrangulación que conlleva.

WARNING. READ CAREFULLY.

(EN)

1. The cradle must be placed on a flat floor.
2. Children must never be left alone close to the cradle.
3. In case that any piece is broken or the cradle brakes, then it must not be used until it's repaired.
4. The cradle should never be used by one child who may sit, put on his knees or stand up.
5. All assembling fittings and screws must be well adjusted to avoid damages on your baby.
6. The textile accessories should not be never used without its main structure.
7. The height of the mattress must be that when the mattress base is on its highest position, the distance from the top is 200mm at least.
8. We advise you always to use mattresses "non mites" and those who let the baby breath normally.
9. Be aware you of the fire danger that any source of heat can cause.
10. Always put on the break of the wheels of the cradle while the baby is alone.
11. The screws should never be on loose so the child can pinch his clothes and get caught with strangulation hazard involved.

ATENÇÃO. LER ATENTAMENTE

(PT)

1. O mini-berço deve ser situado sobre um solo horizontal.
2. Não é conveniente deixar as crianças brincar sem vigilância perto do miniberço.
3. No caso de se estragar alguma peça ou que o mini-berço esteja bem, não devesse utilizá-lo até à sua reparação.
4. Quando o bebé se conseguir sentar, ajoelhar ou levantar-se, não deverá utilizar mais o mini-berço para esse bebé.
5. Todos os dispositivos de montagem devem estar sempre ajustados e os parafusos perfeitamente apertados para evitar qualquer perigo para o bebé.
6. O têxtil do mini-berço não deverá ser usado sem o suporte.
7. A espesura do colchão até a parte superior dos laterais, seja no mínimo de 200 mm, com a base na posição mais alta.
8. Aconselhamos sempre colchões que evitem a asfixia e com propriedades anti-ácaros.
9. Advertimos para o perigo de incendio quando haja uma fonte de calor nas proximidades do mini-berço, como aparelhos eléctricos de aquecimento, de gás, etc...
10. Bloquear as rodas do mini-berço enquanto o bebé não estiver a ser vigiado.
11. Os parafusos não devem perder e a criança pode beliscar ou roupas fiquem presas com o perigo de Estrangulamento envolvidos.

(FR)

- ATTENCION

1. Le moisés doit être correctement situé sur une surface horizontale.
2. Ne convient pas laisser jouer aux enfants près du moïse sans aucune surveillance.
3. Si quelque pièces se casse ou bien se case le moïse ne doit pas être utilise avant son réparation.
4. Ne pas utiliser le moïse si l'enfant peut s'asseoir, se mette à genoux o se lever tout seul.
5. Tous les dispositifs de montage doivent être toujours très bien réglés et les visseries bien serrés pour éviter des perills aux enfants.
6. Le vêtement du moïse ne doit pas être utilisé sans son structure.
7. Le matelas du moïse doit avoir une épaisseur de sorte que des la surface du matelas jusqu'à la partie supérieure des côtés, soit, au moins, de 200 mm avec la base à la position la plus haute.
8. Nous vous conseillons d'utiliser toujours des matelas qui évitent l'asphyxie et qui soit antiacares.
9. Nos vous avertissons du périll d'incendie si vous avez de source de chaleur près du moïse, ainsi comme des appareils électriques chauffage, gaz...
10. Bloquer les roues de moïse quand le bébé est seul.
11. Les vis ne doivent pas lâche et l'enfant peuvent pincer ou attraper des vêtements avec le danger de étranglement impliqués.

(IT)

ATTENZIONE. LEGGERE ATTENTAMENTE.

1. La culla deve essere adeguatamente collocata in orizzontale.
2. Non si consiglia di lasciare giocare i bambini da soli senza sorveglianza alcuna nelle prossimità della culla.
3. Se per caso si dovesse spezzare qualche pezzo, la culla non va utilizzata finché non sarà sistemata.
4. Quando un bambino sia in grado di sedersi, inginocchiarsi oppure tirarsi su da solo, la culla non va più utilizzata da quel bambino.
5. Tutti i dispositivi di montaggio devono essere sempre perfettamente montati e le viti perfettamente serrate per evitare eventuali pericoli nei confronti del bambino.
6. Il tessile della culla non va utilizzato senza il proprio sostegno.
7. Il materasso da utilizzare deve avere uno spessore in modo che dalla superficie del materasso alla parte superiore delle pareti, ci siano almeno 200 mm insieme alla base nella posizione più alta.
8. Si consiglia sempre d'utilizzare dei materassi in modo da evitare e anche l'utilizzo di materassi anti-acaro.
9. Vorremmo avvertire del pericolo d'incendi dovuti alla presenza di calore in prossimità della culla, come ad esempio riscaldamento elettrico, gas, ecc ...
10. Bloccare le ruote della culla, mentre il bambino rimane in esso incustodito.
11. Le viti non deve perdere e il bambino può schiacciare o abiti vengano con il pericolo di strangolamento coinvolti.

(RU)

ВНИМАНИЕ! ВНИМАТЕЛЬНО ПРОЧТИТЕ.

1. Колыбель должна быть удобно установлена на ровном месте .
2. Не следует оставлять без присмотра детей играть в непосредственной близости от колыбели .
3. Если части колыбели сломаны или повреждены , колыбель не должна использоваться до проведения ремонта .
4. Когда ребенок сможет самостоятельно сидеть , стоять на коленях , колыбель не должна больше использоваться для этого ребенка .
5. Во избежание опасности для ребенка все устройства и детали должны быть установлены и винты всегда затянуты .
6. Корзина колыбели не должна использоваться без Вашей поддержки .
7. Матрас , который будет использоваться , должен иметь такую толщину , чтобы от поверхности матраса до верхнего края колыбели было не менее 200 мм при самом верхнем положении ложа .
8. Всегда выбирайте матрасы «против удушья» и анти-клещевые .
9. Во избежание опасности пожара не устанавливайте колыбель рядом с электрическими приборами , батареями отопления , газовыми плитами и т.д.

(CN)

1. 摇篮应便于安放在水平地面上。
2. 附近无人看管时，不应让儿童在摇篮中单独玩耍。
3. 任何部件如有损坏，或摇篮有破损，修好前不要使用。
4. 当孩子可以单独坐、跪或站时，就不应再使用此摇篮。
5. 所有安装组件都务必正确调节并拧紧螺钉，以免给婴儿带来危险。
6. 摇篮的吊篮在未装支架时不应使用。
7. 所用床垫应有一定的厚度，从而使底板处于最高位置时，床垫表面到两侧上部的距离至少为 200 毫米。
8. 我们建议务必使用床垫，以避免窒息和有防螨作用。
9. 当摇篮附近有热源，如电暖器、燃气等时，应注意发生火灾的危险。
10. 当孩子处于无人看守时，应锁住摇篮车的车轮。
11. 注意螺钉不能松动，以免夹伤孩子或钩住其衣服，发生勒颈窒息的危险。

西班牙制造

ةيانعب ةءارقلا .مامتءال -

1. ةيوتسم ضرراً لىل ع عقى رييرسلا نوكى نأ بجى .
2. رييرسلا طيحم يف بع ل دحو فارش! نود لافطال كرت يغبني ال .
3. ءالصل! ىتح ىسوم مءختست نأ يغبني ال رسك وأ ،ءزج ي رسك بت ام اذا! .
4. لفظلا اءهل رشك! امءاءختسا نكمي ال سىسيوم ،ءدحو فوقول وأ عوكرل ،سولجل اعيطتسي لفظلا نوكى امءنع .
5. لفظلا لىل ع رطخ ي ابن جت رييرسلا اربأ تءءشو امامت اءل يءت امءاء ءءءصءمءل ءزهءال اعيمى لىل ع بجى .
6. مءمء نود مءختست نأ ىسوم ءلس يغبني ال .
7. بصلنم لىل ع ءءءق عم لمء 200 نع لقى ال يولءل ابنءال لىل شارءلءل ءطس نم ءىءب ءءءمءس اءل مءاءءءسءال شارء لىل ع بجى .
8. سوس صىءاصءو قانءءال اعنمءل شرفلءل مءءءءسءاب امءاء يصون .
9. ... ءلا زاءال ءىءابرهءلءل ءىءءءلءل ءم نم ءبىرءلءل قءانمءل يف ءرارءل ءوءع نم مءانلءل قىرءلءل رطخ رءءل .
10. بءارمءل رىء ءىء لءازى ال لفظلا نأ نىء يف رييرسلا نم ءالءءل اعنم .
11. ءىءنءمءل قانءءال رطخ عم سبءالمءل ءءقوا لصلء نأ نكمى وأ ءصءرء لفظلءل او رييرسلا لىل ع ءلءل فوس .