

Silver Cross[®]

Simplicity Infant Carrier

Group 0+ Birth to 13kgs (29lbs)
Birth to approximately 9-12 months

Suitable for:
3-point lap and diagonal seat belt
Universal Approval

Attaching to the Simplifix ISOFIX Base
Semi-Universal Approval

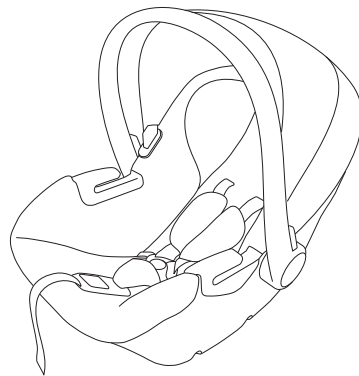

IMPORTANT, RETAIN FOR FUTURE REFERENCE: READ CAREFULLY

Please keep the instructions in the compartment provided in the back of the Simplicity Infant Carrier. To protect your baby correctly the Silver Cross Simplicity Infant Carrier must always be installed and used as per the manufacturer's instructions.



VERY IMPORTANT

Please read the whole of this instruction guide carefully. Failure to do so could put your baby in danger. You can only expect the Simplicity Infant Carrier to provide maximum protection if it is fitted and used correctly as per the manufacturer's instructions.

The Simplicity Infant Carrier must always be rearward facing (with your baby facing the back of the vehicle)

This infant carrier can be used from birth to 13kgs (29lbs) birth to approximately 9-12 months using a 3 point lap and diagonal seat belt approved to UN ECE Regulation 16 or equivalent standards.

You must never fit the Simplicity with a 2 point lap belt.

⚠ NEVER use the Simplicity Infant Carrier on a passenger seat fitted with a front airbag. It is VERY DANGEROUS AND ILLEGAL.

POSSIBLE SEATING POSITIONS

(providing that the infant carrier is fitted in accordance with the user guide).

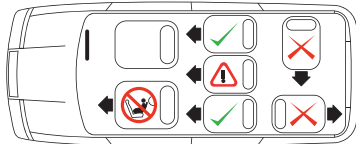

⚠ Must be fitted as per manufacturers instructions.

VERY IMPORTANT

Not all car seats fit all cars. **“Try Before You Buy”** Make sure that it fits correctly and is suitable for your child. You must be comfortable and confident when installing the infant carrier and always install it as per the manufacturer's instructions.

If you require any further advice as to the suitability of this restraint system for your vehicle please contact Silver Cross customer services on **0845 8726900**

There is a Simplifix ISOFIX Base which can be purchased separately if your vehicle/s is suitable, see Vehicle Application List. This could be especially helpful if you have a short seat belt.

The Simplicity Infant Carrier is tested and approved to ECE R44.04. This approval is invalidated if you make any modifications to the Simplicity Infant Carrier. No modifications may be made other than by the manufacturer.

Contents

- 3-4 Important: Safety Guide
- 4-5 Parts List
- 6-7 Get to know your Simplicity Infant Carrier
- 8-9 Before you install the Simplicity Infant Carrier in the vehicle
- 10-13 Fitting and removing your baby from the Simplicity Infant Carrier
- 14 Methods of installation
- 14-16 Installing and removing the Simplicity Infant Carrier
- 17 Troubleshooting
- 18 Installing the Simplicity Infant Carrier on a Silver Cross Travel System
- 18 Using the Simplicity Infant Carrier as a rocking seat
- 18 Using the Simplicity Infant Carrier as a baby seat
- 18-19 Looking after your Simplicity Infant Carrier
- 19 Final check list before your journey
- 20 Warranty and Notice

Important: Safety Guide

 **NEVER use the Simplicity Infant Carrier on a passenger seat fitted with a front airbag. It is VERY DANGEROUS AND ILLEGAL.**

Read the whole instruction manual and make sure you fully understand how to fit and use the Simplicity Infant Carrier correctly.

Always keep your instruction manual in the compartment provided on the Simplicity Infant Carrier.

 **It is very important to make sure that when the child restraint is positioned on the vehicle seat it is at the correct angle and not too upright so that breathing is not restricted especially with very small and light/premature babies. This could lead to breathing restrictions.**

Silver Cross recommend that you do not place anything under the Simplicity Infant Carrier, it could affect the performance of the infant carrier in an accident.

Never buy a second hand infant carrier, it may have unseen damage which could affect the safety of your child.

Always replace the Simplicity Infant Carrier after an accident, it may have unseen damage which could affect the safety of your baby.

Always secure the Simplicity Infant Carrier by the 3 point lap and diagonal seat belt when not in use.

All occupants in the vehicle must be correctly restrained complying with the current law.

Loose objects in the vehicle should be secured when travelling.

Cover the Simplicity Infant Carrier if it is left in direct sunlight. Plastic and metal surfaces get very hot and could burn. The car seat cover is also likely to fade.

The safety harness must be used at all times when a baby is in the Simplicity Infant Carrier.

Before carrying the Simplicity Infant Carrier make sure that the handle is firmly locked in the carry position.

Do not make unauthorised modifications or alterations to the Simplicity Infant Carrier.

The Simplicity Infant Carrier must never be used without the manufacturer's recommended seat cover being correctly fitted. If you replace the seat cover, only use one recommended by the manufacturer.

It is very important that the harness chest pads and buckle pad are always fitted and positioned correctly. They are an important safety feature.

Do not allow children to play with or adjust the Simplicity Infant Carrier.

Avoid leaving your baby in the Simplicity Infant Carrier for long periods. Take your baby out for frequent breaks.

Do not leave children alone in your car.

Do not place the Simplicity Infant Carrier on a table or work top, always use the floor.

Never leave your baby unattended in the Simplicity Infant Carrier either in or outside the car.

Make sure that all folding vehicle seats are securely latched and fastened.

Important: Safety Guide (cont.)

Make sure that the Simplicity Infant Carrier or its adjusting strap does not become trapped in the door of the vehicle or by a folding passenger seat. Do not allow the adjusting strap to be caught in moving parts such as doors, escalators etc.

Always store the Simplicity Infant Carrier in a safe, dry place when it is not being used.

Avoid storing the Simplicity Infant Carrier near a direct heat source such as a radiator and do not place heavy objects on top of the Simplicity.

Child car seats can mark vehicle seat upholstery and seat belts. Silver Cross cannot be held responsible for damage or marking to vehicle seats and seat belts.

Silver Cross strongly recommend that when using the Simplicity Infant Carrier whether in or out of the vehicle that you take your child out at regular intervals especially on long journeys. This will help relieve pressure on the baby's spine and lower back area.

Simplicity Infant Carrier parts list

- 1 Handle in the carrying & rocking position.
- 2 Push buttons for adjusting handle
- 3 Safety Harness: Shoulder belts with chest pads
- 4 Safety Harness: Crotch strap with buckle comfort/protection pad
- 5 Safety Harness: Harness buckle
- 6 Slots for shoulder straps
- 7 Harness release button
- 8 Harness adjuster strap
- 9 Seat belt lap section guides (Colour coded blue-rearward facing only)
- 10 Apron
- 11 UV protected sun/wind canopy
- 12 Sun/wind canopy connection points
- 13 Head support
- 14 Support wedge
- 15 Diagonal section seat belt guide (colour coded blue-rearward facing only)
- 16 Instruction manual compartment
- 17 Infant carrier base & pram chassis release
- 18 Locking latches for connection to base and suitable pram models.

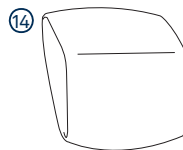
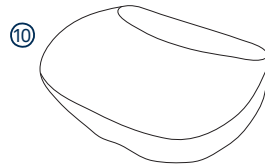
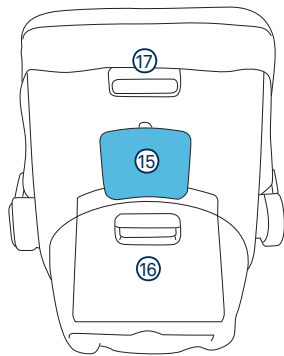
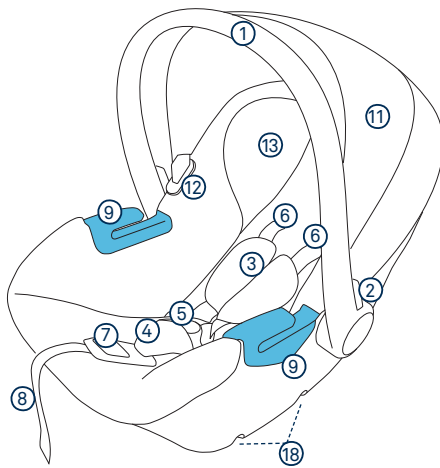

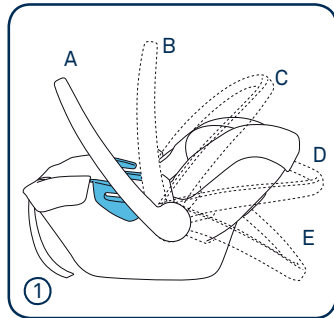

Get to know your Simplicity Infant Carrier

Different handle positions

- ① Make sure you understand the different handle positions and can correctly adjust the handle to the required position.

- A** In car position
- B** Carrying and rocking position
- C** Helps access in and out
- D** Storage position (boxed)
- E** Stable position

Handle Operation

- ② Push in and hold **BOTH** handle release triggers located on the sides of the handle. Move the handle to the required position making sure that both sides click into position.

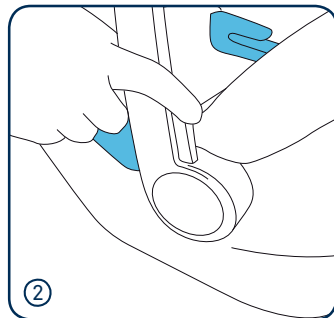

The head support and lumbar wedge

The built in head support is designed to give extra side protection and support for your baby's head and will automatically re-position when the harness is adjusted. The lumbar wedge helps provide a more supportive seating position especially for new and premature babies.

The lumbar wedge can be removed in the later stages of using the Simplicity Infant Carrier. Silver Cross always recommend that you use the wedge for as long as possible.

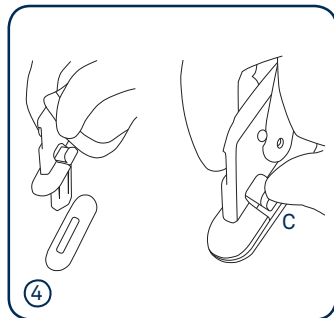
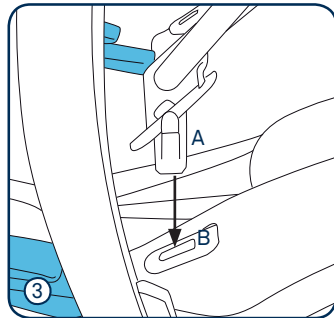

Fitting and using the sun/wind canopy

- ③ Place the Simplicity Infant Carrier on a level floor surface with the handle positioned in the stable position.

Remove your baby from the Simplicity Infant Carrier.

To fit the sun/wind canopy slide the two plastic attachment arms (A) into the holes located on either side of the Simplicity Infant Carrier (B).

Make sure that both plastic attachment arms are positioned and locked correctly into the fixing holes.

Make sure that the fabric of the sun/wind canopy is positioned around the back of the infant carrier shell. Holding the rim of the sun/wind canopy, gently pull the front frame of the canopy forward to fully open.

- ④ To remove the sun/wind canopy, press the release levers (C) on both arms and remove

Fitting and using the apron

The apron is designed to be used when the Simplicity Infant Carrier is attached to the Silver Cross pushchair.

The apron can be fitted by placing it over the foot end of the Simplicity Infant Carrier, gently pull into position and secure using the Velcro tabs **only when not fitted in the vehicle.**

⚠ The apron MUST NOT be used when the Simplicity Infant Carrier is fitted into the vehicle as the buckle release button will be obscured.

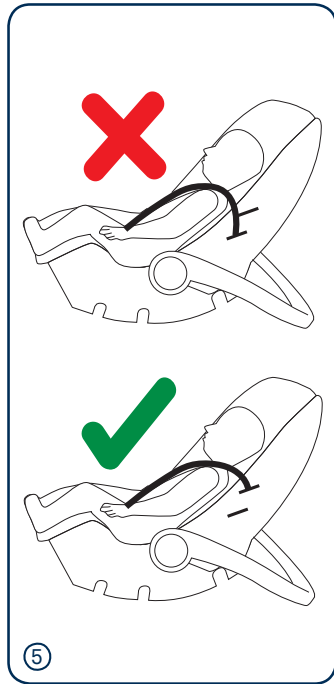

Before you install the Simplicity Infant Carrier in the vehicle

Harness position

⑤ Before you install the Simplicity Infant Carrier it is very important that you make sure the shoulder straps are at the right height for your baby. **The shoulder straps should be level or just below your baby's shoulders.**

NOTE: Winter/Summer clothing can make a difference to the size of your baby.

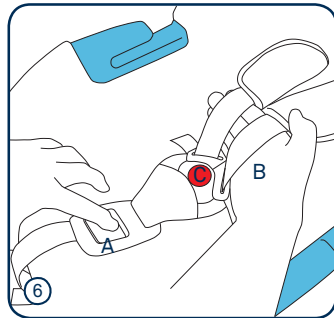

Harness adjustment

Place the Simplicity Infant Carrier on a level floor surface with the handle in the stable position.

- ⑥ Slacken the shoulder straps by pressing the harness release button (A) at the same time, pulling **both** shoulder straps forward below the chest pads with your other hand (B). Press the red release button (C) and undo the harness.

Carefully place your baby in the Simplicity Infant Carrier and identify the correct shoulder position.

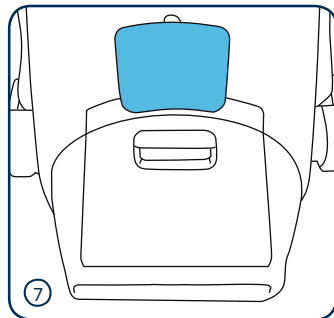

- ⑦ Open the instruction manual compartment at the rear of the infant carrier shell and locate the adjustment handle.

- ⑧ Release the handle and adjust the shoulder straps to the required position. Push the handle back into the new position and make sure it clicks correctly into the notched groove. Close the instruction manual compartment lid. The inner head support will have altered position so that it corresponds with the new harness shoulder position.

Check that the shoulder straps are in the correct position for your baby's shoulders.

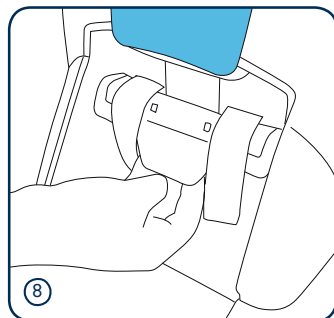

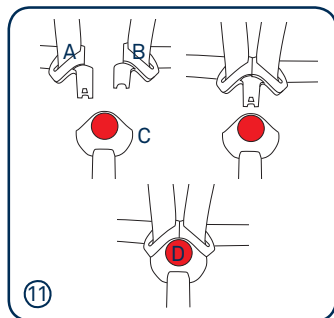
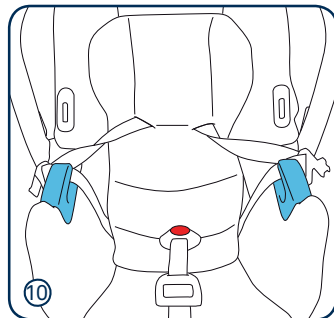
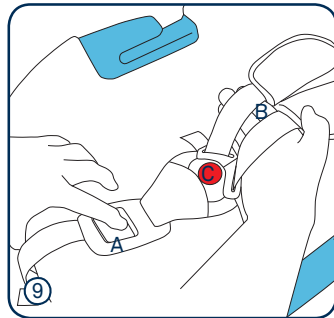

10

Fitting and removing your baby from the Simplicity Infant Carrier

Operating the harness

⚠ Your child must be fastened in the safety harness at all times when using the Simplicity Infant Carrier.

- ⑨ Place the Simplicity on a level floor surface and the handle in the stable position.
Slacken the shoulder straps by pressing the harness release button (A) and at the same time, pulling both shoulder straps forward below the chest pads with your other hand (B).
Unfasten the harness by pressing the red release button (C)
- ⑩ Place the shoulder straps over the sides of the infant carrier.
Place your baby in the Simplicity Infant Carrier and check that the shoulder straps are in the correct position for your baby's shoulders (see point 5 p.8). Correctly position the 5 point harness over the child making sure there are no twists.
- ⑪ Fit the shoulder strap tongues (A) and (B) together and then push firmly into the crotch strap buckle (C) until you hear a click.

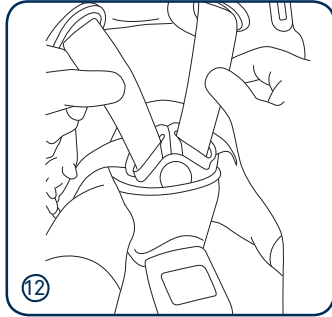

- ⑫ To remove slack from both sides of the waist section of the harness pull the shoulder straps upwards towards you.
- ⑬ Tighten the harness straps by pulling the harness adjuster strap (A) until the baby is secure.
- ⑭ Again pull both shoulder straps upwards towards you to remove any further slack from both sides of the waist section of the harness.

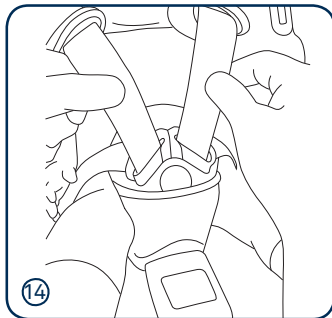
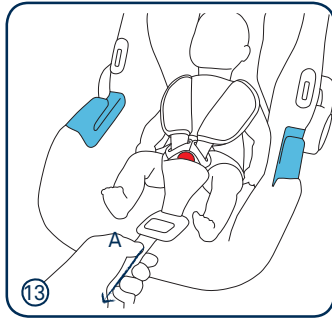

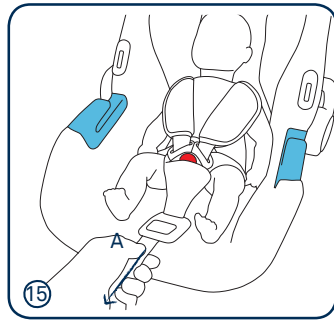

- 15 Fully tighten the harness straps by further pulling the harness adjuster strap (A) until the baby is secure.

The harness must fit the child firmly but not make the child uncomfortable. It is important that the buckle rests low on the baby's pelvic area and not on the stomach. Make sure the chest pads and buckle pad are in position. They are an **IMPORTANT** safety feature and should always be used.

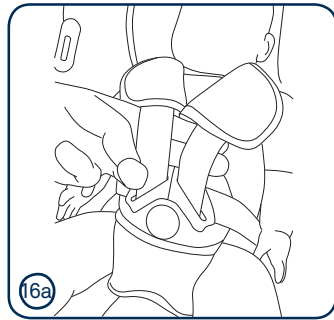

16 You should only be able to insert 2 fingers between the shoulder straps and the waist straps.

17 To remove your child from the Simplicity Infant Carrier, slacken the shoulder straps by pressing the harness release button (A) and at the same time, pulling both shoulder straps forward below the chest pads with your other hand (B).

Unfasten the harness by pressing the red buckle release button (C) and place the shoulder straps over the side of the infant carrier.

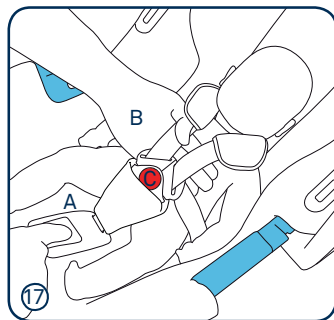
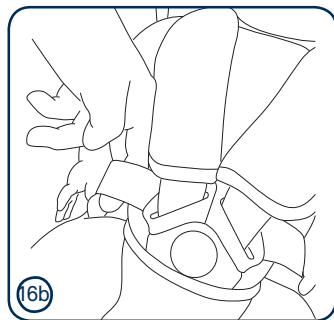

Methods of installation

The Simplicity Infant Carrier is approved for two different methods of installation.

1. With the vehicle 3-point lap and diagonal seat belt (Universal Approved)
2. With the Simplifix ISOFIX Base (Semi-Universal Approved).

The Simplifix ISOFIX Base is sold separately.



Installing and removing the Simplicity Infant Carrier

⚠ NEVER use the Simplicity Infant Carrier on a passenger seat fitted with a front airbag. It is VERY DANGEROUS AND ILLEGAL.

Using a 3 point lap and diagonal seat belt to install the Simplicity Infant Carrier

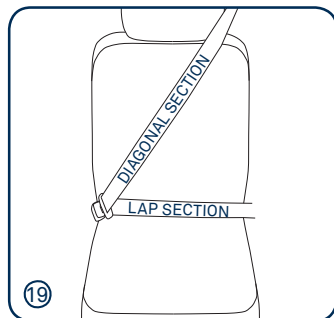

- 18 Place the Simplicity Infant Carrier on the vehicle seat with your baby facing the back of the vehicle. The Simplicity Infant Carrier must ALWAYS be rearward facing with your baby facing the back of the vehicle.
- 19 The Simplicity Infant Carrier must ALWAYS be fitted using a 3 point lap and diagonal seat belt.

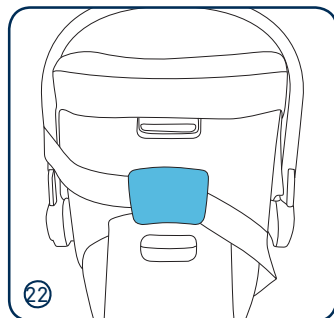
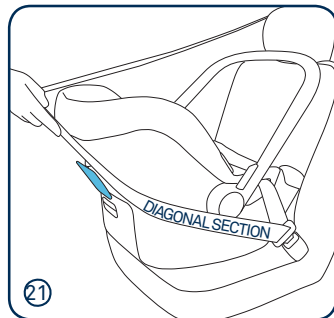
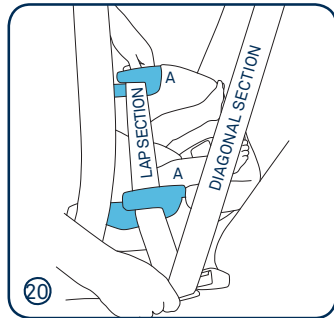

Using a 3 point lap and diagonal seat belt to install the Simplicity Infant Carrier (cont)

- 20 Slowly pull the seat belt out across the Simplicity Infant Carrier and fasten the seat belt. Pass the **lap section** of the seat belt through both blue lap belt guides (**A**). Pull the diagonal section of the seat belt to remove any slack in the lap section.
- 21 Pull the **diagonal section** of the seat belt around the back of the Simplicity Infant Carrier.
- 22 Place the **diagonal section** of the seat belt securely into the blue diagonal belt guide positioned on the back of the Simplicity Infant Carrier. Holding the Simplicity Infant Carrier firmly pull the diagonal section of the seat belt to remove any slack.

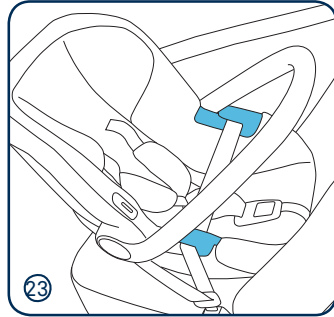

Installing and removing the Simplicity Infant Carrier (cont)

Using a 3 point lap and diagonal seat belt to install the Simplicity Infant Carrier (cont)

- 23 Check that the angle of the Simplicity Infant Carrier back rest is not too upright and make sure that the seat belt is not twisted. Push firmly into the back of the Simplicity Infant Carrier, it should feel tight and secure. There should be no excessive movement forward or to the side.

NOTE: The seat belt guides are colour coded BLUE because it is a REARWARD FACING ONLY child restraint.

Removing the Simplicity Infant Carrier from the vehicle

Remove the diagonal section of the seat belt from the blue diagonal belt guide. Unfasten the seat belt and remove the belt out of the blue lap section guides taking care to hold the seat belt away from your baby. Carefully remove the Simplicity Infant Carrier from the vehicle using the carry handle in the upright carry position.

Make sure the handle has CLICKED into the correct position.

Troubleshooting

Common Problems	Possible Solutions
Seat belt too short	<p>Try different seating position</p> <ul style="list-style-type: none"> • Adjust vehicle seat as far back as possible • Position seat belt height adjuster to the lowest position (where fitted) <p>Pull the seat belt tight removing any slack</p>
<p>Infant carrier unstable or too upright due to shape of vehicle seat</p> <p> IMPORTANT: Do not try and alter the vehicle seat shape. For example: filling gaps, altering the angle of infant carrier</p>	<p>Try different seating position</p>
Seat belt buckle too long, cannot fully tighten lap section of seat belt	<p>Try different seating position</p>
Seat belt buckle is too far forward	<p>Try different seating position</p>

**For further advice:
contact the retailer where you purchased the infant carrier**

Installing the Simplicity Infant Carrier on a Silver Cross travel system

The Simplicity Infant Carrier is designed to fit specified Silver Cross pushchairs. Please refer to your pushchair instructions.

Using the Simplicity Infant Carrier as a rocking seat

Place the Simplicity Infant Carrier on a level floor surface. Move the handle making sure the handle firmly clicks into the rocking position (see page 6).

 **Your baby must be harnessed into the infant carrier and never left unattended.**

Using the Simplicity Infant Carrier as a baby seat

Place the Simplicity Infant Carrier on a level floor surface. Move the handle making sure the handle firmly clicks into the stable position. You can now use the Simplicity Infant Carrier as a baby seat.

 **Your baby must be harnessed into the infant carrier and never left unattended.**

Looking after your Simplicity Infant Carrier

Removing the covers

 **You must never use your Simplicity Infant Carrier without the manufacturer's cover. It is an important safety feature of the infant carrier.**

To remove the cover, open the velcro fastening chest pads and remove.

First remove the head support cover by opening the two press studs and remove the head support cover from the plastic insert.

To remove the cover, undo the two press studs, undo the harness buckle and then pull out the eight connecting studs situated at the sides of the cover. Slide the harness and buckle through the cutouts in the cover, pull the cover over the sides of the infant carrier and remove the cover.

Refitting the covers

Pull the cover over the sides of the infant carrier. Make sure the internal safety harness is threaded through the cutouts in the cover. Insert the cover into the sides of the two blue seatbelt guides and the two sun/wind canopy connection points. Fasten the eight connecting studs, and the two press studs to complete the refitting of the cover.

Slide the head support cover over the plastic insert, and slide the shoulder straps through the head support cover, fasten the two press studs to complete the refitting of the cover.

Open the velcro fastening on the chest pads and refit.

Make sure there are no twists in the harness.

 **It is very important that the chest pads are refitted. They are an important safety feature, and should always be used.**

Cleaning the infant carrier shell and harness

Wipe clean using a mild hand soap and warm water. You must not use detergents, solvents or strong soaps. This may weaken your infant carrier shell or harness. You must not remove, dismantle or alter any part of the infant carrier shell or harness. You must not oil or lubricate any part of your infant carrier shell or harness.

Cleaning the covers and chest pads

Hand wash only at a maximum of 30 degrees (see wash care label on the back of the Simplicity Infant Carrier seat cover). Do not iron, dry clean or tumble dry. Dry flat, away from direct heat and sunlight.

Cleaning the crotch strap buckle

Clean the crotch strap buckle with a mild hand soap and water and then thoroughly rinse with warm water. Leave to dry and DO NOT OIL OR LUBRICATE any part of the buckle.

Final checklist before journey

Check

- The Simplicity Infant Carrier must always be rearward facing (with your child facing the back of the vehicle).
- **You have NOT fitted the Simplicity Infant Carrier on a passenger seat fitted with a front airbag.**
- You have adjusted the harness to the correct position.
- The handle is firmly clicked into the "In Car Position" see p.6.
- You have correctly routed the vehicle 3 point lap and diagonal seat belt as per the manufacturer's instructions.
- The Simplicity Infant Carrier is tight and secure with no excessive movement forward or to the side.

Warranty

All Silver Cross products are guaranteed for a period of 12 months against faulty workmanship, when the product is used correctly according to the instruction manual.

Notice (Universal)

1. This is a "Universal" child restraint. It is approved to Regulation No.44.04 series of amendments, for general use in vehicles and it will fit most, but not all, car seats.
2. A correct fit is likely if the vehicle manufacturer has declared in the vehicle handbook that the vehicle is capable of accepting a "Universal" child restraint for this age group.
3. This child restraint has been classified as "Universal" under more stringent conditions than those which applied to earlier designs which do not carry this notice.
4. If in doubt, consult either the child restraint manufacturer or the retailer.
5. Only suitable if the approved vehicles are fitted with 3 point static/ with retractor safety-belts, approved to UN ECE Regulation No 16 or other equivalent standards.

IMPORTANT: If this child restraint is used with the Silver Cross Simplifix ISOFIX Base (sold separately) the category of this child restraint is "semi-universal" and it is only suitable for installation in the vehicles and in the seat positions indicated in the vehicle application list. The vehicle application list is supplied with the Simplifix ISOFIX Base.

Le siège auto Simplicity doit toujours faire face vers l'arrière (votre enfant doit être tourné vers l'arrière du véhicule).

Ce siège enfant peut être utilisé de la naissance à 13 kg (29 lb) (jusqu'à 9-12 mois environ) avec une ceinture de sécurité en 3 points dotée d'une sangle abdominale et d'une sangle diagonale, homologuée conformément au règlement n° 16 de la CEE/ONU ou à des normes équivalentes.

Vous ne devez jamais utiliser le siège Simplicity avec une ceinture de sécurité en 2 points.



N'utilisez JAMAIS le siège auto Simplicity sur un siège passager dont l'airbag est activé. C'est TRES DANGEREUX ET ILLEGAL.

Important : Guide de sécurité

N'utilisez JAMAIS le siège auto Simplicity sur un siège passager dont l'airbag est activé. C'est TRES DANGEREUX ET ILLEGAL.

Lisez le manuel d'instructions dans sa totalité et assurez-vous de bien comprendre comment régler et utiliser correctement le siège auto Simplicity.

Rangez toujours votre manuel d'instructions dans le compartiment du siège auto Simplicity prévu à cet effet.

Vous devez impérativement veiller à ce que le dispositif de retenue pour enfants soit correctement positionné sur le siège du véhicule (pas trop droit) pour que l'enfant puisse respirer normalement, surtout avec des bébés prématurés et de très petite taille. Un mauvais positionnement peut entraîner des difficultés respiratoires.

Silver Cross recommande de ne rien placer sous le siège auto Simplicity, car cela risquerait de réduire la performance du siège auto en cas d'accident.

N'achetez jamais un siège auto d'occasion, car il peut comporter des dommages invisibles, ce qui risquerait de compromettre la sécurité de votre enfant.

Remplacez toujours le siège auto Simplicity après un accident, car il peut comporter des dommages invisibles, ce qui risquerait de compromettre la sécurité de votre enfant.

Attachez toujours le siège auto Simplicity à l'aide de la ceinture de sécurité abdominale et diagonale en 3 points lorsque vous ne l'utilisez pas.

Tous les occupants du véhicule doivent être correctement attachés, conformément à la législation en vigueur.

Les objets mobiles doivent être immobilisés à l'intérieur du véhicule lorsque vous voyagez.

Recouvrez le siège auto Simplicity s'il est directement exposé aux rayons du soleil. Les surfaces en plastique et en métal peuvent devenir très chaudes et provoquer des brûlures. La housse du siège auto risque aussi de se décolorer.

Le harnais de sécurité doit être utilisé à tout moment lorsqu'un enfant est assis dans le siège auto Simplicity.

Avant de transporter le siège auto Simplicity, assurez-vous que l'anse est bien verrouillée en position de transport.

Ne faites aucune modification ou transformation non autorisée sur le siège auto Simplicity.

FR-IT-ES-CH-RU

Le siège auto Simplicity ne doit jamais être utilisé si la housse du siège recommandée par le fabricant n'est pas correctement ajustée. Remplacez toujours la housse du siège par une autre housse recommandée par le fabricant.

Les coussinets de poitrine et le protège-boucle du harnais doivent toujours être correctement ajustés et positionnés. Ces éléments sont essentiels pour la sécurité de votre enfant.

Ne laissez pas les enfants jouer ou régler le siège auto Simplicity.

Ne laissez pas votre enfant trop longtemps dans le siège auto Simplicity. Sortez-le du siège de temps en temps.

Ne laissez pas les enfants seuls dans la voiture.

Ne mettez pas le siège auto Simplicity sur une table ou un plan de travail, posez-le toujours par terre.

Ne laissez jamais votre enfant sans surveillance dans le siège auto Simplicity à l'intérieur ou à l'extérieur du véhicule.

Assurez-vous que tous les sièges rabattables du véhicule sont correctement bloqués.

Assurez-vous que le siège auto Simplicity ou la sangle de réglage n'est pas coincé dans la portière du véhicule ou sous le siège passager rabattable. Faites en sorte que la sangle de réglage ne puisse pas se prendre dans des pièces en mouvement, comme des portes ou des escaliers mécaniques.

Rangez toujours le siège auto Simplicity dans un endroit sécurisé et sec lorsque vous ne l'utilisez pas.

Évitez de ranger le siège auto Simplicity à proximité d'une source de chaleur directe, comme un radiateur, et ne posez pas des objets lourds sur le siège auto.

Les sièges auto peuvent laisser des marques sur le revêtement des sièges et les ceintures du véhicule. Silver Cross ne peut être tenu responsable des dommages ou des marques laissées sur les sièges et les ceintures du véhicule.

Silver Cross vous recommande fortement de sortir régulièrement votre enfant de son siège, que vous utilisiez le siège à l'intérieur ou à l'extérieur du véhicule, surtout lorsque vous faites de longs trajets. Cela permettra de soulager la colonne vertébrale et la partie lombaire de votre enfant.



Votre enfant doit être attaché avec le harnais de sécurité chaque fois que vous utilisez le siège auto Simplicity.



Votre enfant doit être attaché dans le siège auto et ne doit jamais être laissé sans surveillance.



Votre enfant doit être attaché dans le siège auto et ne doit jamais être laissé sans surveillance.



Vous ne devez jamais utiliser le siège auto Simplicity sans la housse du fabricant. La housse fait partie intégrante du siège auto et est essentielle à la sécurité de l'enfant.

 **Vous devez absolument replacer les coussinets de poitrine. Ils protègent votre enfant et doivent être utilisés en permanence.**
Nettoyage de la coque et du harnais du siège auto

Nettoyez avec du savon doux pour les mains et de l'eau chaude. N'utilisez pas de détergents, de solvants ou autres savons agressifs. Cela risque de réduire la performance de la coque ou du harnais de votre siège auto. Vous ne devez pas retirer, démonter ou modifier les parties de la coque ou du harnais du siège auto. Vous ne devez pas graisser ou lubrifier les parties de la coque ou du harnais de votre siège auto.

Nettoyage de la housse et des coussinets de poitrine

Lavez à la main à maximum 30 degrés (voir l'étiquette de lavage à l'arrière de la housse du siège auto Simplicity). Pas de repassage, de nettoyage à sec ni de séchage en machine. Séchez à plat, loin d'une source de chaleur directe et de la lumière du soleil.

Nettoyage de la boucle de la sangle d'entrejambe

Nettoyez la boucle de la sangle d'entrejambe avec un savon doux pour les mains et de l'eau, puis rincez abondamment avec de l'eau chaude. Laissez sécher et **NE GRAISSEZ PAS** ou **NE LUBRIFIEZ PAS** les parties de la boucle.

Il portabebè Simplicity va sempre collocato in senso contrario alla marcia (con il bambino rivolto verso la parte posteriore della vettura).

Il portabebè può essere utilizzato dalla nascita a 13 kg di peso (dalla nascita a fino a che il bambino non avrà 9-12 mesi) e si fissa al veicolo con una cintura di sicurezza a 3 punti addominale e pettorale omologata in conformità al regolamento UN ECE 16 o a norme equivalenti.

Non installare mai il portabebè Simplicity utilizzando una cintura a 2 punti statici.

 **Non utilizzare MAI il portabebè Simplicity su un sedile dotato di airbag frontale. È MOLTO PERICOLOSO E NON È CONTEMPLATO DALLA LEGGE.**

Importante: Guida per la sicurezza

Non utilizzare MAI il portabebè Simplicity su un sedile dotato di airbag frontale. È MOLTO PERICOLOSO E NON È CONTEMPLATO DALLA LEGGE.

Leggere attentamente l'intero manuale delle istruzioni per comprendere pienamente come installare ed utilizzare correttamente il portabebè Simplicity.

Tenere sempre il manuale di istruzioni nell'apposito compartimento sul portabebè Simplicity.

È molto importante verificare che il portabebè sia posizionato sul sedile della vettura alla giusta angolazione e non in una posizione troppo verticale per evitare di ostacolare la corretta respirazione del bambino, specialmente in caso di bimbi molto piccoli e leggeri o di bimbi prematuri. La mancata

osservanza di questa istruzione potrebbe ostacolare la corretta respirazione del bambino.

Silver Cross raccomanda di non posizionare alcun oggetto sotto al portabebè Simplicity; potrebbe influire sulle prestazioni del portabebè in caso di incidente.

Non acquistare mai un portabebè di seconda mano; potrebbe avere danni non visibili che potrebbero influire sulla sicurezza del bambino.

Sostituire sempre il portabebè Simplicity dopo un incidente; potrebbe riportare danni non visibili che potrebbero influire sulla sicurezza del bambino.

Anche se non in uso, fissare sempre il portabebè Simplicity con la cintura di sicurezza a 3 punti addominale e pettorale.

È necessario che tutti gli occupanti della vettura indossino correttamente le cinture di sicurezza in conformità alle leggi vigenti.

Altri eventuali oggetti nella vettura dovranno essere fissati durante il viaggio.

Il portabebè Simplicity va coperto se lasciato alla luce diretta del sole. Le superfici metalliche e quelle di plastica possono surriscaldarsi e provocare ustioni. Anche la fodera tende a scolorire.

Quando il bimbo è nel portabebè Simplicity, dovrà sempre essere utilizzata l'imbracatura di sicurezza.

Prima di trasportare il portabebè Simplicity accertarsi che il manico sia saldamente bloccato nella posizione di trasporto.

Non apportare modifiche o alterazioni non autorizzate al portabebè Simplicity.

Il portabebè Simplicity non deve mai essere utilizzato senza che la fodera raccomandata dal produttore non sia stata inserita correttamente. Utilizzare esclusivamente una fodera raccomandata dal produttore qualora fosse necessario sostituirla.

È molto importante che le imbottiture delle cinghie spalle e della fibbia dell'imbracatura siano sempre inserite e posizionate correttamente. Sono importanti per la sicurezza del bambino.

Non permettere ad altri bambini di giocare o di cambiare la regolazione del portabebè Simplicity.

Evitare di lasciare il bambino per lungo tempo nel portabebè Simplicity. Togliere spesso il bambino dal portabebè (pause frequenti).

Non lasciare il bambino solo nell'auto.

Non appoggiare il portabebè Simplicity su di un tavolo o su un piano di lavoro rialzato, ma posizionarlo sempre sul pavimento.

Indipendentemente che ci si trovi all'interno o all'esterno dell'automobile, non lasciare mai il bambino incustodito nel portabebè Simplicity.

Accertarsi che tutti i sedili ribaltabili della vettura siano correttamente fissati e ancorati.

Accertarsi che il portabebè Simplicity o la cintura regolabile non rimangano incastrati nello sportello della vettura o in un sedile passeggeri ribaltabile. Fare attenzione perché la cintura regolabile non rimanga incastrata in parti mobili quali porte, ascensori ecc.

Quando non utilizzato, conservare sempre il portabebè Simplicity in un luogo sicuro e asciutto.

Evitare di conservare il portabebè Simplicity vicino ad una fonte diretta di calore, come ad esempio un termosifone, ed evitare di collocare oggetti pesanti sul portabebè.

È possibile che i seggiolini per bambini lascino segni sulla tappezzeria o sulle cinture di sicurezza della vettura. Silver Cross non sarà responsabile di eventuali danni o segni presenti sui sedili e sulle cinture di sicurezza della vettura.

Quando si utilizza il portabebè Simplicity, indipendente che ci si trovi nella vettura o fuori della vettura, Silver Cross raccomanda di far scendere il bambino dal portabebè ad intervalli regolari, specialmente in caso di viaggi di lunga durata. Questa precauzione è importante per alleviare la tensione a livello lombare e alla colonna vertebrale del bambino.



Quando utilizzate il portabebè Simplicity il bambino deve essere sempre allacciato all'imbracatura di sicurezza.



Il bambino deve sempre essere assicurato al portabebè e mai lasciato incustodito.



Il bambino deve sempre essere assicurato al portabebè e mai lasciato incustodito.



Mai utilizzare il portabebè Simplicity senza la fodera fornita dal produttore. È un elemento fondamentale per la sicurezza del portabebè.



È molto importante ricollocare le imbottiture delle cinghie spalle, perché sono un elemento di sicurezza fondamentale e devono sempre essere utilizzate.

Pulizia della scocca e dell'imbracatura del portabebè

Per la pulizia utilizzare un sapone delicato per le mani e acqua tiepida. Non utilizzare detergenti, solventi o saponi aggressivi che potrebbero diminuire la resistenza della scocca o dell'imbracatura del portabebè. Non togliere, smontare o alterare nessuna parte della scocca o dell'imbracatura del portabebè. Non lubrificare nessuna parte della scocca o dell'imbracatura del portabebè.

Pulizia della fodera e delle imbottiture delle cinghie spalle

Lavare esclusivamente a mano a una temperatura massima di 30° (vedere l'etichetta di lavaggio situata nella parte posteriore della fodera del portabebè Simplicity). Non stirare, né centrifugare, né lavare a secco. Lasciare asciugare su una superficie piana ed evitare fonti di calore e la luce diretta del sole.

Pulizia delle fibbie della cintura spartigambe

Pulire la fibbia della cintura spartigambe con un sapone delicato per le mani e acqua; sciacquarla bene con acqua tiepida. Lasciarla asciugare e NON USARE NESSUN TIPO DI OLIO O LUBRIFICANTE in nessuna parte della fibbia.

El portabebés Simplicity siempre debe colocarse contra la marcha (con el bebé mirando hacia la parte trasera del vehículo).

Este portabebés se puede utilizar a partir del nacimiento y hasta los 13 kg (desde el nacimiento hasta aproximadamente los 9-12 meses) utilizando un cinturón de seguridad de 3 puntos diagonal y abdominal en conformidad con el reglamento UN ECE 16 o una normativa equivalente.

Nunca sujete el Simplicity con un cinturón abdominal de 2 puntos.

 **NUNCA UTILICE el portabebés Simplicity en el asiento del copiloto si hay airbag frontal. Es SUMAMENTE PELIGROSO, ADEMÁS DE ILEGAL.**

Importante: Guía de seguridad

NUNCA utilice el portabebés Simplicity en el asiento del copiloto si hay airbag frontal. Es SUMAMENTE PELIGROSO, ADEMÁS DE ILEGAL.

Lea el manual de instrucciones en su totalidad y asegúrese de entender por completo cómo colocar y utilizar el portabebés Simplicity correctamente. Conserve el manual de instrucciones en el compartimento que incorpora el portabebés Simplicity.

Es muy importante que se asegure de que el sistema de retención del niño se coloque en el vehículo con el ángulo correcto y no demasiado vertical para no dificultar la respiración, sobre todo en el caso de bebés prematuros, muy pequeños o que pesen poco. Esto podría dificultar la respiración.

Silver Cross recomienda que no se coloque nada debajo del portabebés Simplicity, ya que podría afectar al rendimiento del portabebés en caso de accidente.

Nunca compre un portabebés de segunda mano; es posible que, aunque no sea visible, haya sido dañado y esto podría afectar a la seguridad del niño.

Sustituya sin falta el portabebés Simplicity tras un accidente; es posible que, aunque no sea visible, haya resultado dañado y esto podría afectar a la seguridad del bebé.

Sujete siempre el portabebés Simplicity con el cinturón de seguridad abdominal y diagonal de tres puntos de anclaje cuando no esté en uso.

Todos los ocupantes del vehículo deben ir debidamente sujetos en conformidad con la ley vigente.

Los objetos que pueda haber sueltos por el vehículo deben sujetarse cuando este se encuentre en movimiento.

Tape el portabebés Simplicity si se va a dejar a la luz solar directa. Las superficies de plástico, así como las metálicas, alcanzan temperaturas elevadas y pueden llegar a quemar. Además, es posible que la funda del portabebés pierda el color.

El arnés de seguridad se debe utilizar en todo momento cuando el bebé se encuentre en el portabebés Simplicity.

Antes de mover el portabebés Simplicity, asegúrese de que el asa esté inmovilizada en la posición de transporte.

No realice ninguna modificación ni alteración no autorizadas al portabebés Simplicity.

FR-IT-ES-CH-RU

El portabebés Simplicity nunca se debe utilizar a no ser que la funda recomendada por el fabricante para el asiento se haya colocado correctamente. Si cambia la funda del asiento, utilice únicamente una recomendada por el fabricante.

Es muy importante utilizar y colocar correctamente las almohadillas del arnés para el pecho y la hebilla. Constituyen un dispositivo de seguridad de gran importancia.

No permita que ningún niño juegue con el portabebés Simplicity ni que lo ajuste.

Evite dejar al bebé en el portabebés Simplicity durante períodos prolongados de tiempo. Retire al bebé del portabebés con frecuencia.

No deje a los niños solos en el coche.

No coloque el portabebés Simplicity en una mesa o superficie elevada; utilice siempre el suelo.

Nunca deje al bebé sin vigilancia cuando se encuentra en el portabebés Simplicity, ya sea dentro o fuera del coche.

Asegúrese de que todos los asientos abatibles del vehículo se hayan inmovilizado y de que estén bien sujetos.

Asegúrese de que ni el portabebés Simplicity ni su correa ajustable queden atrapados en la puerta del vehículo ni en los asientos abatibles. No permita que la correa ajustable quede enganchada en partes móviles como puertas, escaleras mecánicas, etc.

Guarde siempre el portabebés Simplicity en un lugar seguro y seco cuando no esté en uso.

Evite guardar el portabebés Simplicity cerca de fuentes directas de calor, como radiadores, y no coloque objetos de mucho peso encima.

Las sillas de coche pueden dejar marcas en la tapicería de los asientos de los vehículos y en los cinturones de seguridad. Silver Cross no se podrá considerar responsable en caso de daño o marcas en los asientos o cinturones de seguridad del vehículo.

Silver Cross recomienda encarecidamente que, cuando se utilice el portabebés Simplicity (ya sea dentro o fuera de un vehículo), se saque al niño a intervalos regulares, sobre todo durante viajes largos. Esto ayudará a aliviar la presión ejercida en la espina dorsal del bebé y en la parte inferior de la espalda.



El bebé debe llevar el arnés abrochado en todo momento cuando utilice el portabebés Simplicity.



El bebé debe llevar el arnés abrochado en el portabebés y nunca se le debe dejar sin vigilancia.



El bebé debe llevar el arnés abrochado en el portabebés y nunca se le debe dejar sin vigilancia.



Nunca debe utilizar el portabebés Simplicity sin la funda del fabricante. Es un importante dispositivo de seguridad del portabebés.



Es muy importante que se vuelvan a colocar las almohadillas del pecho. Constituyen un dispositivo de seguridad de gran importancia y se deben utilizar en todo momento.

Limpieza del armazón y el arnés del portabebés

Límpielos con un jabón de mano suave y agua tibia. No debe utilizar detergentes, disolventes ni jabones fuertes. Es posible que debiliten el armazón o el arnés del portabebés. No debe extraer, desmontar ni alterar ninguna de las partes del armazón o el arnés del portabebés. No debe engrasar ni lubricar ninguna parte del armazón ni del arnés del portabebés.

Limpieza de las fundas y las almohadillas del pecho

Lávese a mano únicamente a 30 grados como máximo (véase la etiqueta con las instrucciones de lavado situada en la parte trasera de la funda del asiento del portabebés Simplicity). No se debe planchar, limpiar en seco ni secar en secadora. Séquese en plano horizontal, sin tender, y lejos de calor directo y de los rayos del sol.

Limpieza de la hebilla de la correa de la entrepierna

Limpie la hebilla de la correa de la entrepierna con un jabón de mano suave y agua, a continuación aclárela con agua tibia. Déjela secar y **NO ENGRASE NI LUBRIQUE** ninguna de sus piezas.

FR-IT-ES-CH-RU

使用时必须将Simplicity婴儿汽车安全座椅面朝后放置（让宝宝面向车的后部）

本婴儿汽车安全座椅适用年龄段为新生婴儿至体重不超过13kg的婴儿，新生婴儿至9-12个月大的婴儿，需使用经认证符合UN ECE第16号法规或同等标准的腰部三点式安全带。

绝不可以给Simplicity婴儿汽车安全座椅装配腰式二点安全带。

 **绝不要在装配了前气囊的座位上使用Simplicity婴儿汽车安全座椅。这样做是极度危险并且违反法律的。**

重要信息: 安全指南

绝不要在装配了前排气囊的座位上使用Simplicity婴儿汽车安全座椅。这样做是极度危险并且违反法律的。

通读使用说明，确保透彻理解Simplicity婴儿汽车安全座椅的正确安装及使用方法。

使用说明手册要放在Simplicity婴儿汽车安全座椅自带的储物格里备查。

在将婴儿安全座椅放在汽车座位上时，一定要确保婴儿安全防护设备角度正确，椅背不能过直，以防婴儿呼吸困难，对于体型小、体重轻或早产的婴儿尤其如此。椅背过直有可能导致呼吸不畅。

Silver Cross建议您不要在Simplicity婴儿汽车安全座椅下面放置任何东西，否则会影响安全座椅在发生事故时的保护作用。

不要购买二手婴儿汽车安全座椅，其破损可能不易察觉，并给您宝宝的安全带来隐患。

在发生交通事故后要更换Simplicity婴儿汽车安全座椅，其破损可能不易察觉，并给您宝宝的安全带来隐患。

在不使用时请用腰部三点式安全带将Simplicity婴儿汽车安全座椅绑定。

车内所有乘客都必须按照现行法律正确使用安全防护装置。

在行车过程中需将零散物品放好。

如果有直接日晒需将Simplicity婴儿汽车安全座椅盖起。塑料、金属表面可能会受热甚至燃烧。汽车椅套也有可能退色。

宝宝在Simplicity婴儿汽车安全座椅里面时必须始终佩戴安全带。

在携带Simplicity婴儿汽车安全座椅前要检查手柄是否牢固锁定在“携带”位置。

未经授权不可擅自改装Simplicity婴儿汽车安全座椅。

不可使用未正确装配制造商指定椅套的Simplicity婴儿汽车安全座椅。椅套如需更换，仅可使用制造商推荐的产品。

一定要保证安全带胸部护垫和安全带扣护垫安装得当，位置准确。它们起到重要的安全保护作用。

不要让宝宝摆弄或调节Simplicity婴儿汽车安全座椅。

不要把宝宝留在Simplicity婴儿汽车安全座椅里面太久。经常抱起宝宝，让宝宝得到休息。

不要把宝宝自己留在车里。

Simplicity婴儿汽车安全座椅不能放在桌子上或其他操作台上，只能放在地上。

不论在车内还是车外，宝宝使用Simplicity婴儿汽车安全座椅时都必须有人看护。

要将所有的可调节的车座锁定或固定。

不要让车门、可调节车座靠背把Simplicity婴儿汽车安全座椅或其调节带夹住。不要让运动部件如门、手扶电

梯等把婴儿汽车安全座椅或其调节带夹住。

在不使用Simplicity婴儿汽车安全座椅时，要找安全、干爽的地方把座椅放好。

不要把Simplicity婴儿汽车安全座椅存放在直接热源附近，比如不要放在暖气周围，也不要安全座椅上放置重物。

儿童汽车安全座椅可能会磨损车座皮饰、安全带。对于此类车座、安全带损坏或磨损，Silver Cross恕不負責。

Silver Cross强烈建议在车内外使用Simplicity婴儿汽车安全座椅时，定时将宝宝抱出休息，旅途漫长的时候更是如此。这样可以缓解宝宝脊柱及后背下部的压力。

 在使用Simplicity婴儿汽车安全座椅过程中，必须全程给宝宝系好安全带。

 您必须给坐在安全座椅里的宝宝系好安全带，并永远保证有人在宝宝身边看护。

 您必须给坐在安全座椅里的宝宝系好安全带，并永远保证有人在宝宝身边看护。

 如果没有制造商提供的保护罩，不可使用Simplicity婴儿汽车安全座椅。这是安全座椅的重要安全防护装置。

 保持胸部护垫的弹性很重要。它们是重要的安全防护装置，必须全程使用。

婴儿汽车安全座椅的外表及安全带的清洁

用温和的洗手液和温水擦拭。不可使用消毒液、溶剂或强力皂液。这可能会减弱婴儿汽车安全座椅外壳或安全带的强度。绝不可以移动、拆除或改动婴儿汽车安全座椅外壳或安全带的任何部分。绝不可以给婴儿汽车安全座椅外壳或安全带的任何部分上机油或润滑剂。

保护罩及胸部护垫的清洁

仅能用不超过30摄氏度的水手洗（见Simplicity婴儿汽车安全座椅椅套背面的洗涤护理标签）不要熨烫、干洗或烘干。平展后晾干，远离直接热源或日照。

胯部安全带扣的清洁

用温和的洗手液及清水清洁胯部安全带扣，之后用温水彻底冲洗。放在一旁晾干，不要给安全带扣的任何部位涂抹机油或润滑剂。

Детское автомобильное кресло Simplicity должно всегда устанавливаться спинкой, повернутой в направлении движения (так, чтобы ребенок сидел лицом к задней части автомобиля).

Это автокресло можно использовать для новорожденных младенцев и детей весом до 13 кг до возраста около 9—12 месяцев при условии использования трехточечного диагонального ремня безопасности, одобренного стандартом UN ECE Regulation 16 или иным эквивалентным стандартом. **Никогда не используйте для кресла Simplicity двухточечный ремень.**



ЗАПРЕЩАЕТСЯ устанавливать детское автокресло Simplicity на пассажирском сиденье с фронтальной подушкой безопасности. **Это ОЧЕНЬ ОПАСНО И ЯВЛЯЕТСЯ НАРУШЕНИЕМ ЗАКОНА.**

Важно: Руководство по безопасности

ЗАПРЕЩАЕТСЯ устанавливать детское автокресло Simplicity на пассажирском сиденье с фронтальной подушкой безопасности. **Это ОЧЕНЬ ОПАСНО И ЯВЛЯЕТСЯ НАРУШЕНИЕМ ЗАКОНА.**

Прочтите инструкцию целиком и убедитесь, что полностью понимаете как правильно установить и использовать детское автокресло Simplicity.

Всегда держите инструкцию в специальном отсеке детского автокресла Simplicity.

Очень важно убедиться, что ребенок располагается на автомобильном сиденье под правильным углом и не в слишком вертикальном положении, чтобы не было затруднений с дыханием. Это особенно важно при транспортировке очень маленьких детей и легких/ недоношенных младенцев. Неправильное размещение может привести к затруднению дыхания.

Компания Silver Cross рекомендует ничего не подкладывать под детское автокресло Simplicity, так как это может повлиять на безопасность автокресла в случае аварии.

Никогда не покупайте подержанное детское автокресло, оно может иметь скрытые повреждения, которые могут подвергнуть опасности вашего ребенка.

Всегда заменяйте детское автокресло Simplicity после аварии, оно может иметь скрытые повреждения, которые могут подвергнуть опасности вашего ребенка.

Всегда пристегивайте детское автокресло Simplicity трехточечным диагональным ремнем безопасности, когда оно не используется.

Все пассажиры должны быть пристегнуты ремнями безопасности согласно действующему законодательству.

Незакрепленные предметы следует зафиксировать перед началом движения автомобиля.

Накройте детское автокресло Simplicity, если оставляете его под прямым солнечным светом. Пластиковые и металлические поверхности сильно нагреваются и могут причинить ожоги. Также может выцвести чехол кресла.

Все время, пока ребенок находится в детском автокресле Simplicity, он должен быть пристегнут ремнями безопасности.

Перед переноской детского автокресла Simplicity проверьте надежно ли зафиксирована ручка в положении для переноски.

Запрещено вносить изменения в конструкцию детского автокресла Simplicity.

Детское автокресло Simplicity нельзя использовать, если рекомендованный производителем чехол кресла не установлен или установлен неправильно. При замене чехла кресла используйте только чехол, рекомендованный производителем.

Очень важно, чтобы нагрудные накладки на ремнях и накладка на пряжке всегда были установлены и размещены правильно. Эти элементы важны для безопасности ребенка.

Не позволяйте детям играть с детским автокреслом Simplicity или регулировать его конструкцию.

Не оставляйте ребенка в детском автокресле Simplicity на длительное время. Делайте частые остановки и вынимайте ребенка из детского автокресла.

Не оставляйте детей одних в машине.

Не ставьте детское автокресло Simplicity на стол, ставьте его только на пол.

Никогда не оставляйте ребенка без присмотра в детском автокресле Simplicity внутри автомобиля или снаружи.

Убедитесь, что все складные автомобильные сиденья надежно закреплены.

Убедитесь, что детское автокресло Simplicity или его регулировочный ремень не будут зажаты дверью автомобиля или складывающимся пассажирским сиденьем. Не давайте регулировочному ремню путаться в движущихся конструкциях, таких как двери, эскалаторы и т.д.

Всегда храните детское автокресло Simplicity в безопасном, сухом месте, когда оно не используется.

Не храните детское автокресло Simplicity рядом с источником тепла, таким как отопительная батарея, и не кладите на кресло тяжести.

Детские автокресла могут повредить обивку автомобильного сиденья и ремни безопасности. Компания Silver Cross не несет ответственность за повреждения или загрязнение автомобильных сидений и ремней безопасности.

Компания Silver Cross настоятельно рекомендует при использовании детского автокресла Simplicity в автомобиле либо вне его регулярно вынимать ребенка из автокресла, особенно при длительных переездах. Это облегчит нагрузку на позвоночник и поясницу ребенка.

 Ребенок должен быть пристегнут ремнем безопасности все время его нахождения в детском автокресле Simplicity.

 Ребенок должен быть пристегнут к автокреслу и не должен оставаться без присмотра.

 Ребенок должен быть пристегнут к автокреслу и не должен оставаться без присмотра.

 Запрещено использовать детское автокресло Simplicity без чехла производителя. Чехол важен для безопасности ребенка.

 Очень важно правильно устанавливать нагрудные накладки на ремнях. Накладки важны для безопасности ребенка, и их следует использовать постоянно.

Чистка каркаса и ремней детского автокресла

Протрите начисто, используя слабощелочное мыло для рук и теплую воду. Нельзя использовать моющие средства, растворители или сильнощелочное мыло. Их воздействие может ослабить конструкцию каркаса или ремень безопасности детского автокресла. Запрещено снимать или изменять какую-либо часть каркаса или ремней детского автокресла. Запрещено смазывать какую-либо часть каркаса или ремней детского автокресла.

Чистка чехлов и нагрудных накладок

Стирать вручную только при температуре до 30 градусов (см. ярлык на задней стороне чехла детского автокресла Simplicity). Запрещено гладить, подвергать химической чистке или сушить в сушильной машине. Сушить в разложенном виде в стороне от источников тепла и прямых солнечных лучей.

Чистка пряжки пахового ремня

Очистите пряжку пахового ремня при помощи слабощелочного мыла для рук и воды, затем тщательно промойте теплой водой. Оставьте на просушку и НЕ СМАЗЫВАЙТЕ какие-либо части пряжки.

Notes:

Silver Cross[®]

Silver Cross (UK) Ltd,
Micklethorn,
Broughton,
Skipton,
North Yorkshire BD23 3JA
United Kingdom

www.silvercross.co.uk
Tel: 0845 872 6900

UNIVERSAL
<0-13kg



XX.XX.XXXX



SXSIMPUK1211W

